

Just For Openers

OCT 1989
ISSUE #44

6126 MCPHERSON ST. LOUIS, MO. 63112

(314) 863-6798

Welcome again to the never ending saga of the opener-it's past-present-future.

1990 CONVENTION

On page 8 is the information for next year's Convention. In order to put on a successful Convention, the hosts need to know how many people are coming. They are volunteering their time for your pleasure. Please, if you are going to the Convention - write to them TODAY!

MEMBERSHIP RENEWAL

This month is also the time to renew your JFO Membership. Since I have the membership cards filled out already, it is not necessary to do them again unless there is a change of address. In order to facilitate the printing of the roster labels please mail your check in TODAY! The cost is still \$12.00.

SUGGESTION

It has been suggested that if other members wish to auction off their trader's, that they do the same as Ed Kaye has been doing. Send me 210 copies of your list and I will insert it free of charge in the following JFO.

Below is a picture of Ed Kaye, gratefully accepting the Phil Fouch Award.



Below is a cartoon from Ollie Hibbeler.

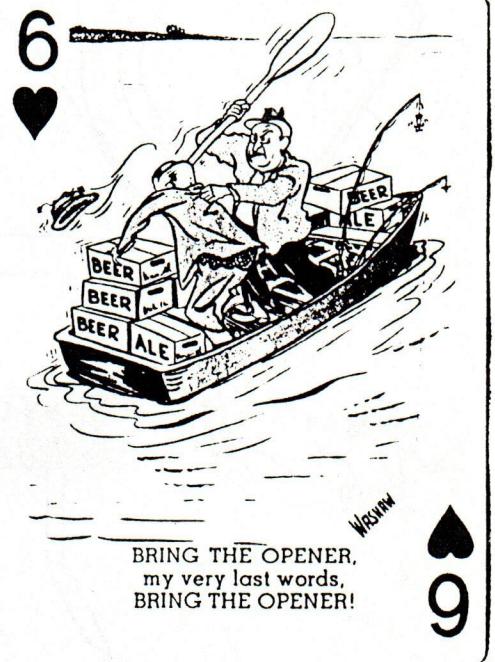

Enclosed in this envelope is Ed Kaye's latest Bid Sheet. Check it over and send it back to him.

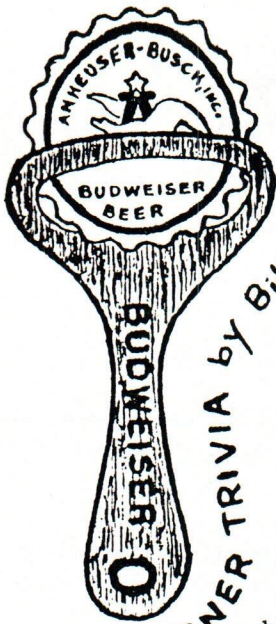

OPENER TRIVIA by Bill McKenzie

This issue of Opener Trivia includes another sampling of some of the nice openers and corkscrews that were available at this year's JFO convention. Ollie Hibbeler whose excellent display of P-1 type cork- (see picture in last issue) took second place had dēz words of wisdom to add: "The Michigan JFO Show had two memorable occurrences for me. I picked up two P-1 corkscrews. The first is the Crescent Brew. Co. Aurora, Ind. and the second is the PATENTED ANHEUSER-BUSCH FEB. 1, 87. However the most memorable experience was the visit we had from our mentor, Capt. Corkscrew. This elusive character and my chance to meet him was worth the trip itself. I doubt that we shall ever see him again. Too bad most of you missed him."

ABOUT THE OPENERS

1 Fil Graff found this nice P-14 type opener/knife from the Southwestern Brewing Co. of Oklahoma City, Oklahoma. This brewery

produced Old King beer from 1936-46.

The blade of the knife is marked: CAMILLUS CUT. CO. CAMILLUS N.Y.

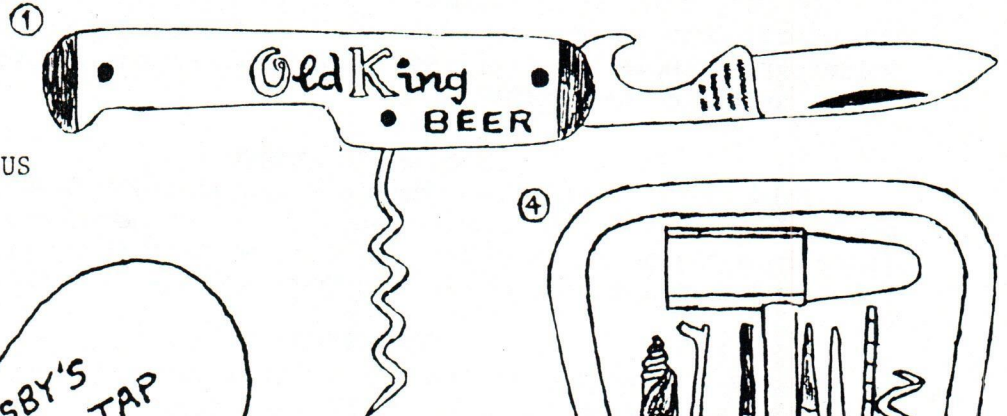

2 & 3 Harold Kogut could not attend this year's convention, but he sent in this excellent drawing of an (next page)

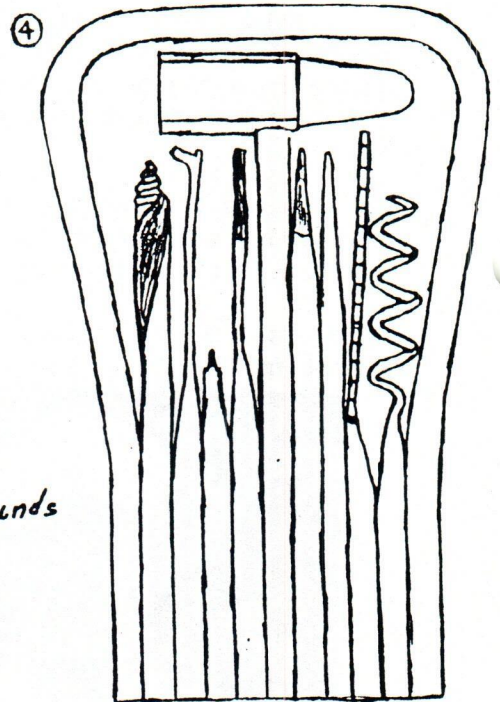
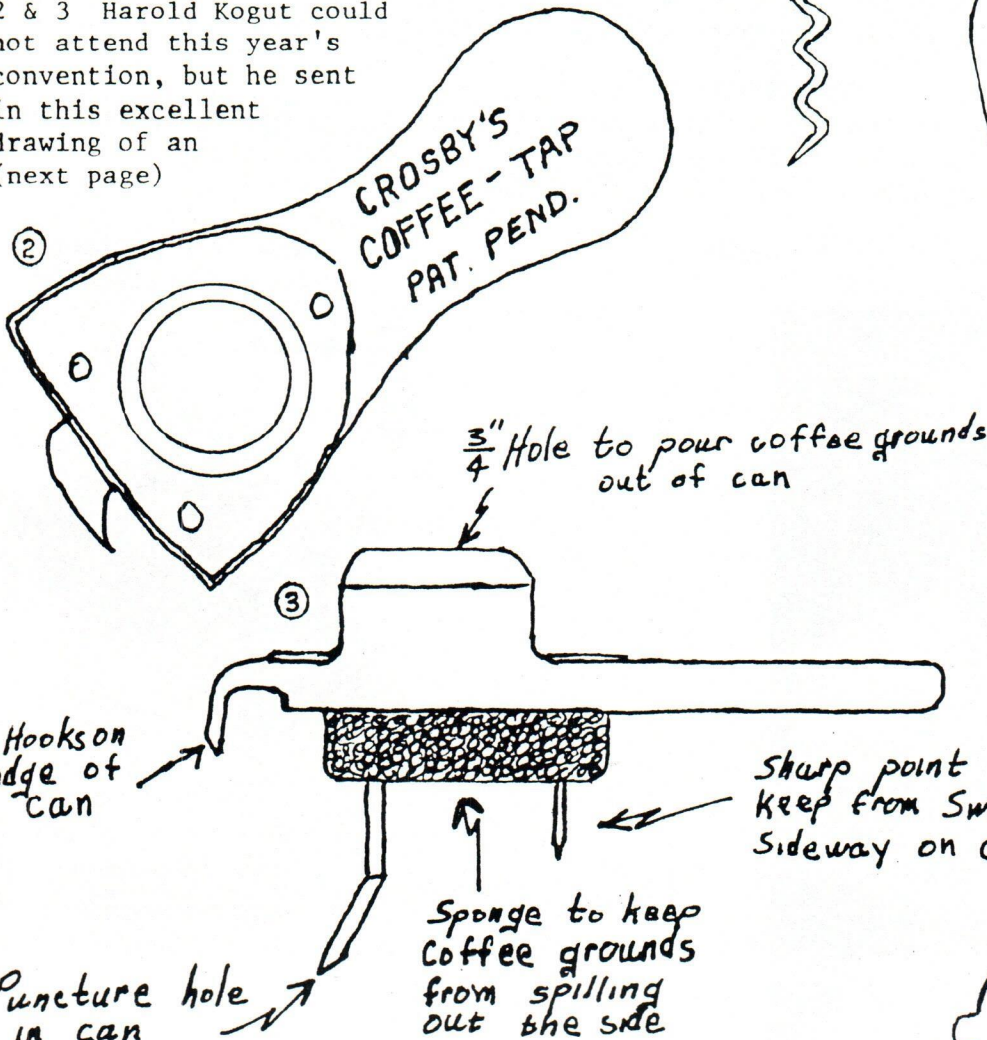

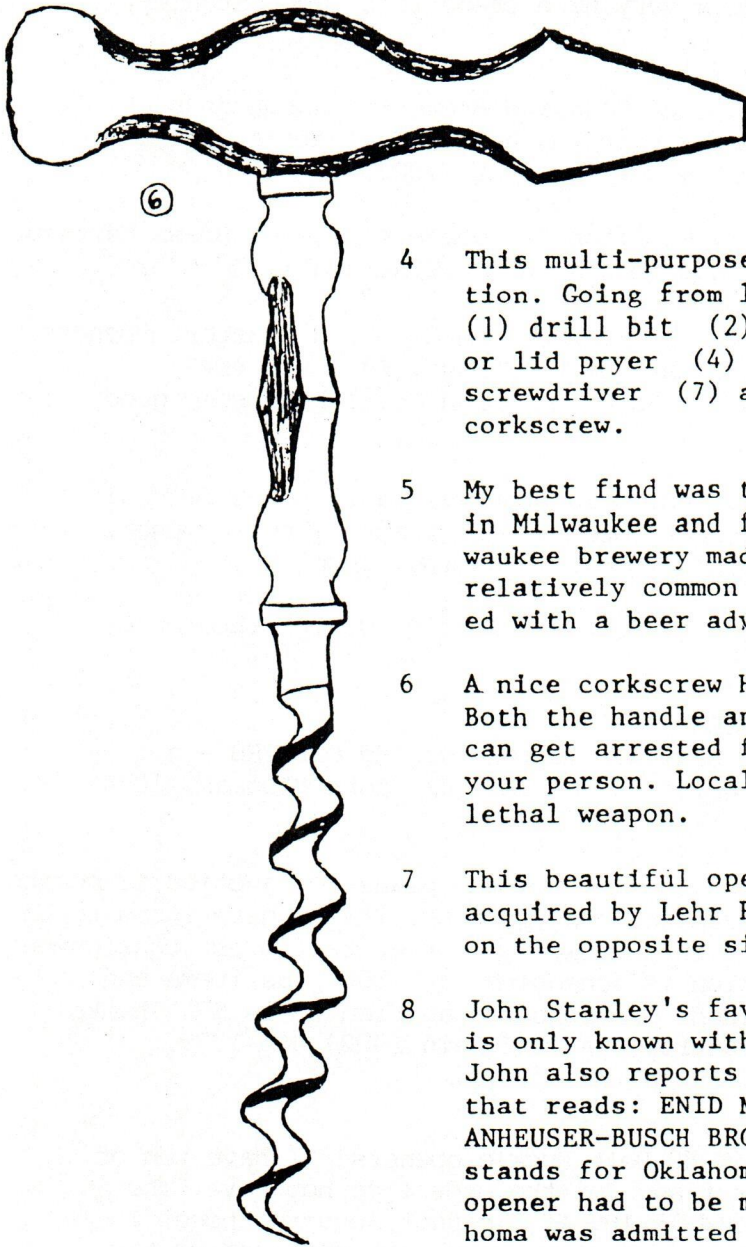

unusual opener he recently found. He thinks it is for pouring coffee grounds out of a coffee can or possibly liquid coffee out of some sort of container. Maybe one of our readers can give us the answer.

- 4 This multi-purpose tool was Art Santen's favorite acquisition. Going from left to left to right it contains: (1) drill bit (2) food can opener (3) small screwdriver or lid pryer (4) bottle opener (5) hammer (6) large screwdriver (7) awl/leather hole punch (8) saw (9) corkscrew.
- 5 My best find was this A-39-1 Gettleman opener. I was born in Milwaukee and finding this difficult type from a Milwaukee brewery made it special to me. Even though it is a relatively common advertising piece it is the only one listed with a beer advertisement.
- 6 A nice corkscrew Herb Danziger added to his collection. Both the handle and shaft are made of metal. In Detroit you can get arrested for having a corkscrew of this size on your person. Local authorities have ruled that it is a lethal weapon.
- 7 This beautiful opener/knife with mother-of-pearl sides was acquired by Lehr Roe. The anchor logo (illustrated) appears on the opposite side of both knife blades.
- 8 John Stanley's favorite opener. This extremely scarce type is only known with this particular advertisement. John also reports he recently found a P-19 type TILE CO. WHOLESALE AGENTS ENID, - O.T. The "O.T." stands for Oklahoma Territory which means that the opener had to be made before 1907, the year Oklahoma was admitted as a state. Two great finds!

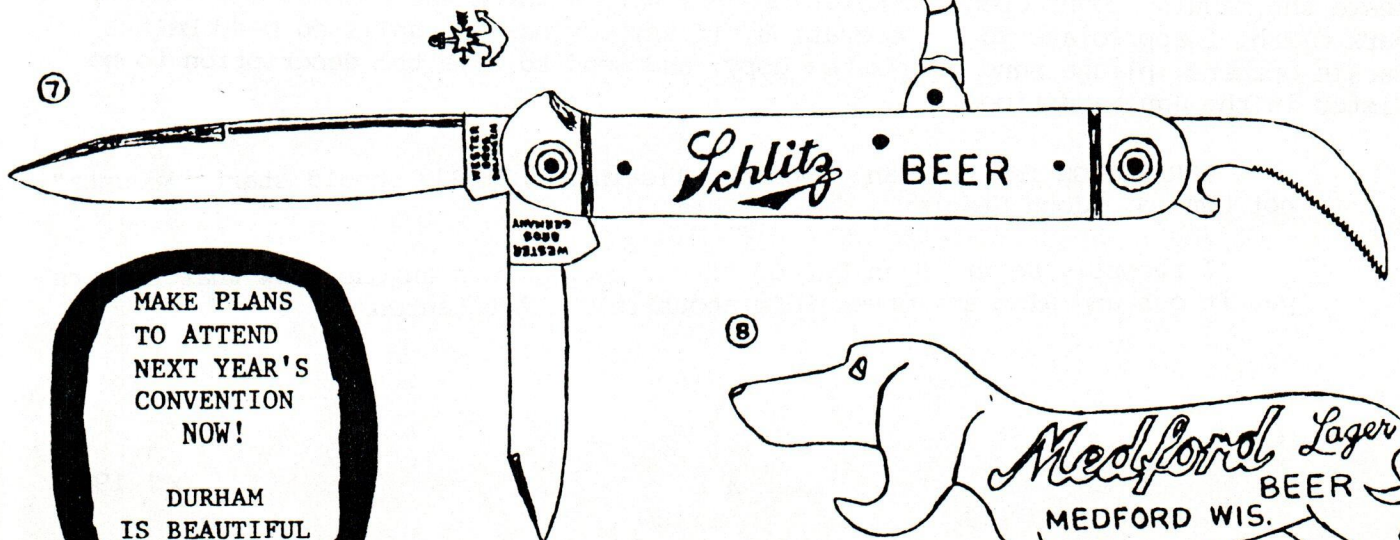

MAKE PLANS
TO ATTEND
NEXT YEAR'S
CONVENTION
NOW!

DURHAM
IS BEAUTIFUL
IN THE
SPRING!

Medford Lager
BEER
MEDFORD WIS.

CLASSIFIEDS

Wanted: Any openers from the following Breweries - Hoster - Columbus, Fink (Penna.), and Star (Ohio - Wooden Shoe Beer). I have a very nice trade list. John Stanley, 605 Windsong Lane, Durham, NC 27713

Wanted: Tokens, Medals, Fobs, etc., of U.S. and Canadian Breweries and Brands of Beer, Ale, etc. Please write first describing what you have. All letters will be answered. George B. Gentle, 510 W. 110th St., New York, NY 10025.

Older Cincinnati, Covington KY, Newport KY, Hamilton OH, openers. Need a Brass Kauffman Brewing Co. from Cincinnati. Henry Smith, 5459 Woodhaven Dr., Cincinnati, OH 45248.

"Zang's Mini Auction": A-21-11 Cataract, B-31-5 Kuebler and C-13-168 Chester. Openers go to highest bidder(s). Deadline 11/15/89. Anthony T. Zanghi, Rd 1 Box 404F14, Coopersburg, PA. 18036. P.S. Any good A&B types PENNA. openers? I have some good traders. Thanks, Tony Z.

Wanted: Lexington Brewery (Dixie Beer) and Coca-Cola openers, want to buy figurals and unusual older openers. Have A, B & C Brewery Openers for trade. Thom Thompson, 123 Shaw Ave. Versailles, KY 40383. (606) 873-8787. Thank You, Thom.

Will trade a P-1-2, A.B. for a P-1-10 Highland Beer and \$15.00. Ollie Hibbeler Jr., 298 Highland Road, Lake Ozark, MO 65049.

NOTICES

John Vlossak has started publishing a two page newsletter called OPENERS - a Correspondence for Corkscrew Collectors. Write to OPENERS, c/o John Vlossak, 1044 East Eldorado St., Appleton, Wis. 54911.

Dear collectors and friends! We are pleased to announce the plans for auction #3 coming up soon. We are now accepting catalog orders and consignments. If you have items to be sold, please call or write for consignment information. We offer the lowest consignment rates of any mail order auction. The auction is scheduled for 1500 plus items and it will be published when this total is reached. Catalogs for auction #3 is \$7. Thanks for your support in the past and in the future. Brad Vifquain (402) 466-1779, Midwest Brewery Auction, 6100 Vine J53, Lincoln, NE, 68505.

I would like to do an article on the N-40 Belt Buckle openers. I have ten of the twenty listed. I would like to buy or trade for the ones I do not have. The openers I need are: N-40-1,3,5,9,10,11,13,14,15,16. If I cannot acquire these, I would like anybody who does have them to xerox the front and back and send me the copies so that I can do a complete picture story of them. To xerox thick openers, leave the machine cover open and cover openers with a thick white sheet and a heavy dark cloth. I appreciate your cooperation. If anybody has any unlisted N-40 Belt Buckle openers, please send me a xerox copy, and send Ed Kaye the description to be listed in the Jan. additions.

CORRECTION for the Jan. 1989 new listings: B21-439 should start "Augusta", not Ugusta. John Stanley

I recently acquired an E-3-66 "Stutz Beer". Does anyone know what Brewers put it out and also any other info about it. Art Santen

LETTERS TO THE EDITOR

Have never seen M-2-1 Lyon or M-2-2 Lyon. Would like to see a photo or picture of either or both if someone has them. John E. Hom, 2828 Chestnut Ln., New Richmond, OH 45157.

To answer McKenzie's question, "I don't know why Fil calls himself "Monk", when I see him, he doesn't act like one." NABA & ABA members (who can read) know that the pen name comes from the Americanized version of the Munich Child (that little person, dressed in black Monk's robes, holding a beer stein and a pretzel and/or horseradish, is the symbol of the Hofbrauhaus (Munich Brewery), and is commonly used as the informal symbol of the city of Munich. The formal symbol has a Monk holding up the Book of Laws in one hand, with the other raised in the Apostolic Blessing).

Bill has evidently missed associating the common old lithographs (both advertising and decorative) of a Monastery cellar scene with anybody he knows. European Monks have been associated with Brewing (as the fine Belgian "Abbey Ales") and Distilling (chartreus and Benedictine Brandys and Cordials) for many centurys. The cellar scenes often show a tonsured (bald, with a rim of hair over the ears, just like me), portly (read "fat") Monk sprawled over or next to a keg of some alcoholic potable. All I need is the brown robe! Bill, a keen observer of human nature, has obviously only seen me ambulatory, though occasionally well on my way to the state described in the old lithos. He is quite correct in his observation that a new find (the odder, the better) is akin to a religious experience to "the Brewer's Monk", but so is the discovery of a new (to me) Beer or Ale!

End of (somewhat pedantic) explanation! Got the picture, Bill?

Fil Graff

THE ALPHABETICAL COMPOSITE OF ADDITIONS THAT APPEARED IN THE JAN. 1985-1989 ISSUES OF JUST FOR OPENERS IS NOW AVAILABLE AS A SUPPLEMENT TO THE HANDBOOK. PRICED AT \$6.00 EACH POSTPAID. ORDER FROM: ED KAYE
1478 ALBATROSS RD.
SANIBEL, FL 33957

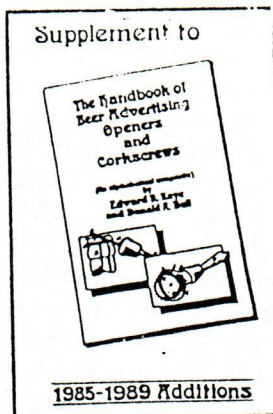

THE MUSEUM OF BEVERAGE CONTAINERS & ADVERTISING
Over 28,000 different beer & soda cans and over 10,000 soda bottles on display along with all types of unique beverage advertising. Also a 2,500 square foot Gift Shop. For more information write or call: Soda Mart \ Can World, Ridgecrest Dr., Goodlettsville, TN 37072, (615) 859-5236

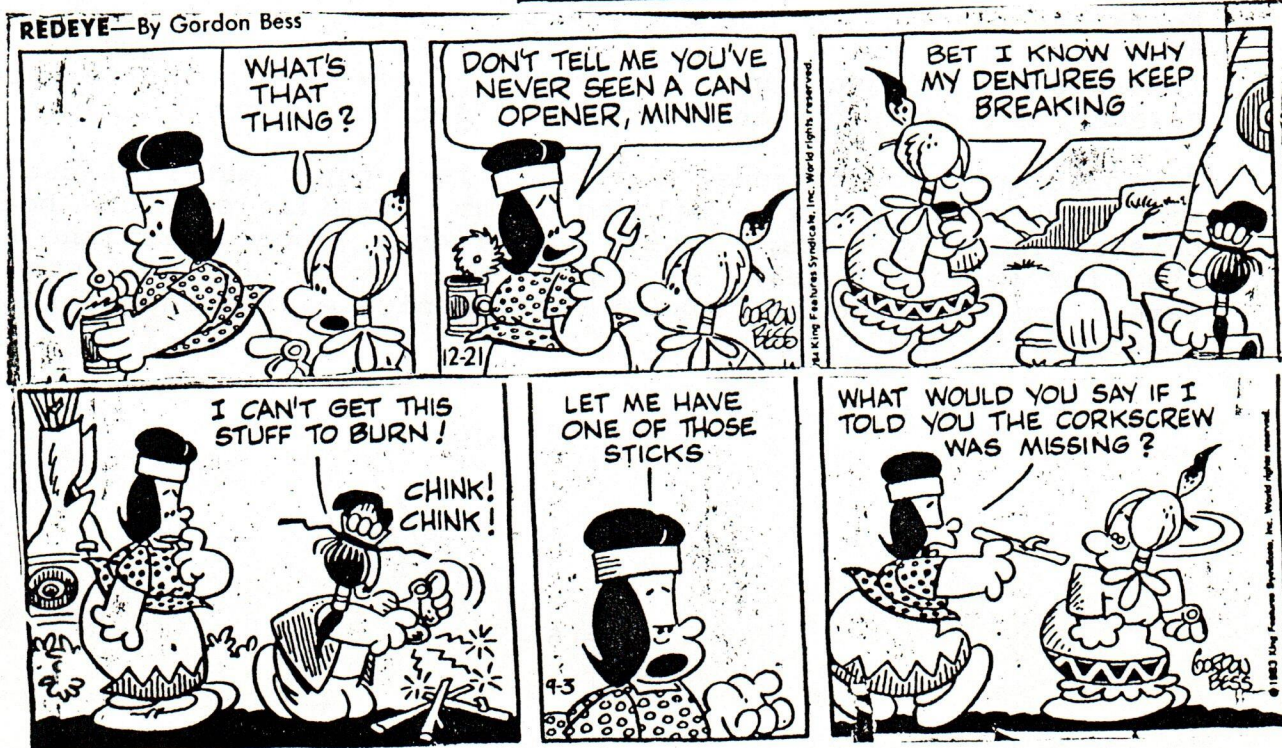

OPENER COLLECTOR OF THE MONTH

To honor the co-sponsors of the last convention, we name Herb as opener collector of this JFO and Lehr as opener collector of the next JFO.

Herbert K. Danziger

550 Cherry Court, Birmingham, MI 48009

313-646-9470

I have a confession to make. I never started collecting corkscrews. My wife, Camille, did. Her first corkscrew was a key made in Poland, a gift from her grandfather. Before we were married, when we were courting (1971), I gave her two more as presents so at that time she had three. Since the definition of a collection is three of anything, Camille now had a corkscrew collection. A little while after that we got married and since we lived in a community property state, I now had half a collection. Not wanting to do anything half way, I proceeded to search for one and one-half more corkscrews to complete my collection. It was fairly easy to pick up the one, but finding half a corkscrew is not the easiest thing in the world to do. Finally I succeeded in acquiring a broken parrot. My collection was whole again. Since then we have added a few more to the collection, a number of which we have found at JFO meetings.

In addition to being a member of the JFO, I am also a member of the International Correspondence of Corkscrew Addicts (ICCA), the Canadian Corkscrew Collectors Club (CCCC), and the Unaffiliated Corkscrew Collectors of Michigan (UCCM). Although the ICCA is usually considered the most difficult in which to gain membership with a limit of 50 members, the UCCM is far more exclusive with only two members, Lehr Roe and me. Half the fun of collecting is being able to talk and visit with other collectors and we have certainly enjoyed being a part of the JFO, ICCA, and the CCCC. I would say the same thing about the UCCM, but one of the members keeps treading in my collecting territory.

As far as specialties are concerned, my collection is pretty much a general one. However, if pressed I would list barscrews, Syroco figurals, champagne taps, and American patents as preferences. However, I usually buy anything that I see that I don't have.

In addition to corkscrews, I also collect paper material dealing with corkscrews and wine-related items. Camille collects beaded purses, letter openers, rabbits and bride & groom dolls (the kind used for wedding cakes). If anyone else in the JFO collects the same items, I would be pleased to communicate with them for buy, trade, and/or sell purposes.

Herb

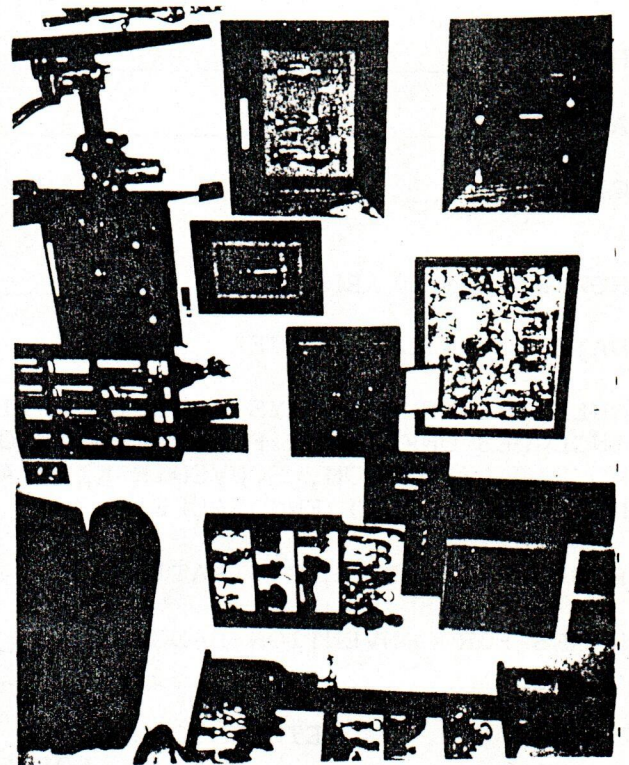
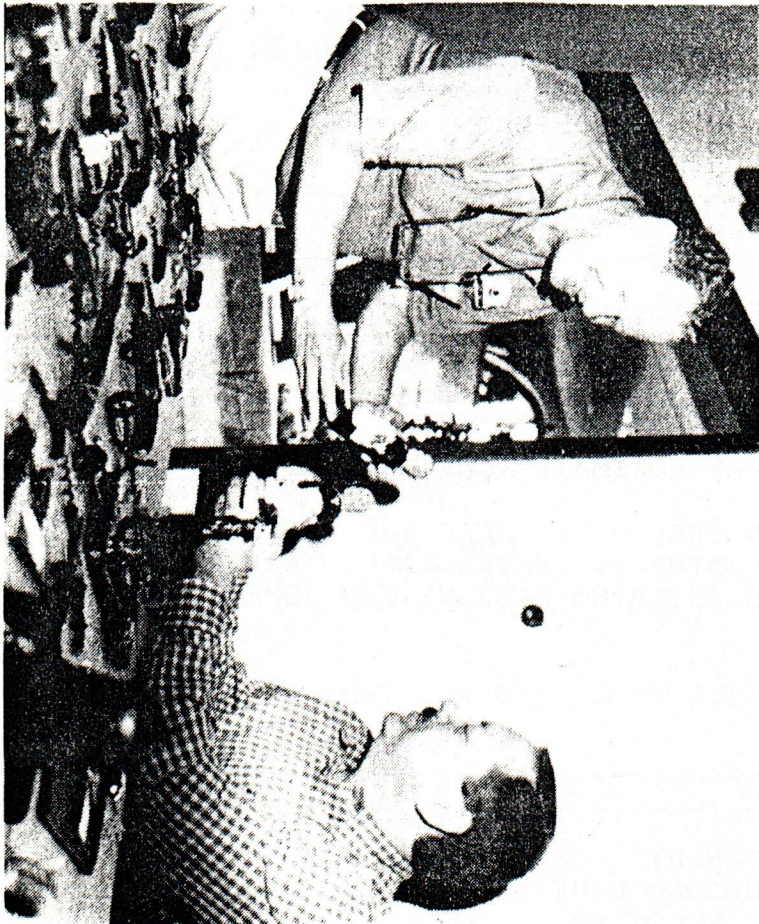
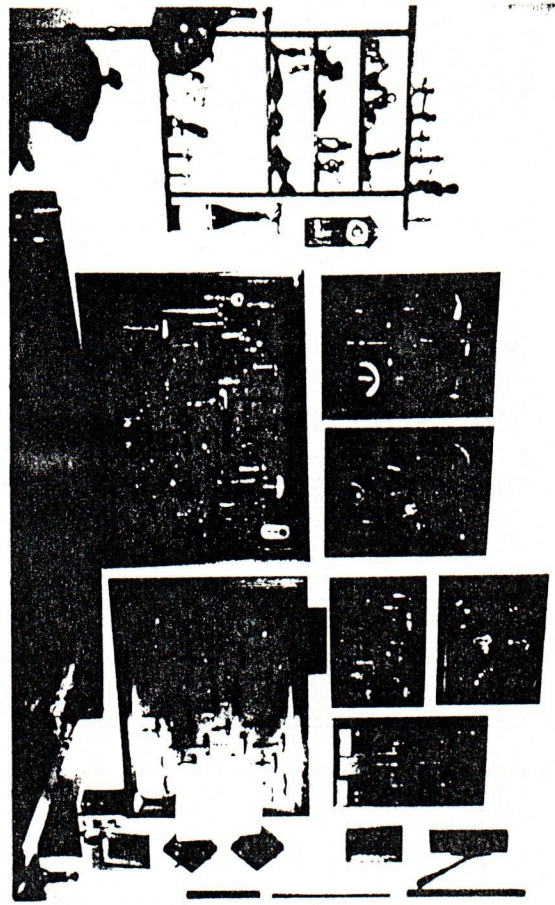
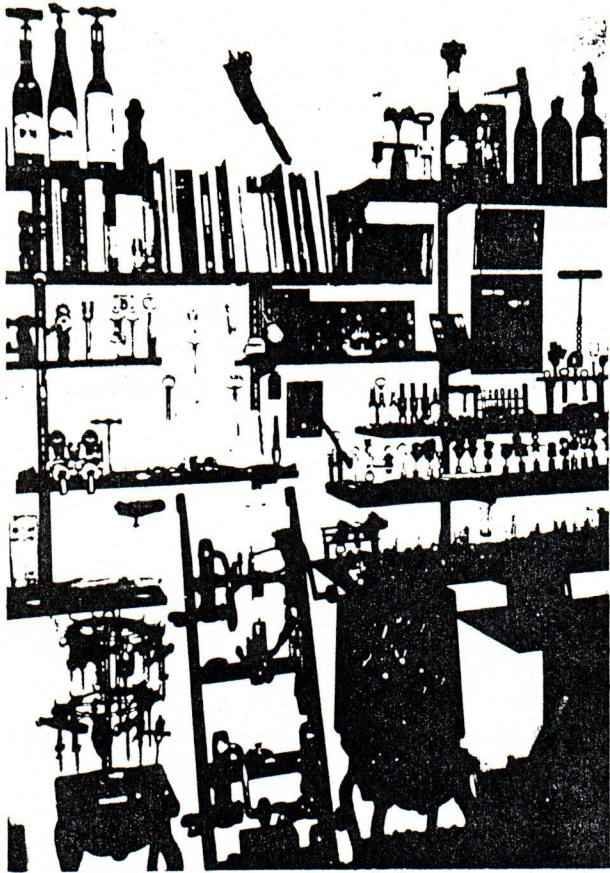

THESE OPENERS DO MORE THAN OPEN CONVERSATION

The Just For Openers national bottle opener club held a three-day convention at the Frankenmuth Bavarian Inn Motor Lodge this past weekend. About 50 people swapped, bought and traded openers, beer paraphernalia and cork screws. Co-sponsors Lehr ROE (left) and Herb Danziger, Michigan residents, show off their unique openers.

JFO CONVENTION QUESTIONNAIRE

CONVENTION TO BE HELD IN DURHAM, NORTH CAROLINA
THURSDAY-SATURDAY APRIL 26, 27 & 28, 1990

- I WOULDN'T MISS IT. HURRAY!!!! (COMPLETE REGISTRATION BELOW)
- I'M STILL TRYING TO WORK OUT A WAY TO ATTEND. KEEP ME INFORMED!
- UNFORTUNATELY I CAN NOT ATTEND. (WISH I COULD).

NAME -----

ADDRESS -----

CITY ----- STATE (PROVINCE) ----- ZIP -----

REGISTRATION FORM

12TH ANNUAL "JUST FOR OPENERS" CONVENTION
THURSDAY-SATURDAY APRIL 26, 27 & 28, 1990
SHERATON UNIVERSITY CENTER (\$54 SINGLE/DOUBLE)
15-501 BYPASS AT MORRENE ROAD
DURHAM, NORTH CAROLINA

NAME -----

ADDRESS -----

CITY ----- STATE (PROVINCE) ----- ZIP -----

HOW WILL YOU ARRIVE? CAR _____ PLANE _____ OTHER _____

DATE YOU WILL ARRIVE _____ APPROXIMATE TIME OF ARRIVAL _____

ONLY THE MEMBER PAYS A REGISTRATION FEE. THIS YEAR THE FEE IS \$30. IT INCLUDES ONE TABLE FOR THE SHOW ON SATURDAY (EXTRA TABLES ARE \$10 EACH), HOSPITALITY ROOM, SOUVENIR KIT, AND ANYTHING ELSE WE CAN COME UP WITH TO MAKE YOUR VISIT ENJOYABLE!

ENCLOSED: \$30 REGISTRATION FEE. \$10 EXTRA TABLE: YES ___ NO ___

NAMES FOR CONVENTION BADGE -----

RETURN TO: JOHN STANLEY
605 WINDSONG LANE
DURHAM, NC 27713
(919) 493-9802

NEW DISCOVERIES

by ART SANTEN

Send New Discoveries to Art Santen. Send Additions to Ed Kaye.

If anybody has any of these N.D. with different names on them, send these Additions to Ed Kaye immediately for inclusion in the Jan. JFO.

B-62 (2 3/8") Coors (M. Benjamin)
B-63 (3 1/8") Buffalo Brewing Company (Ed Kaye)
B-64 (3") Jung Beer (Ed Kaye)
B-65 (2 7/8") Silver Foam [Brew. Battle Creek, MI] (T. Thompson)
S&S Malt Beverage (V. Vollrath)
B-66 (3 1/16") Dubuque Brewing & Malting Co.
B-67 (2 13/16") Key to Jetter's Gold Top Bottle Beer (B. Ennis)
C-40 (3 3/8") Lucky Lager (M. Benjamin)
G-26 (2 1/2") Budweiser (B. Ennis)
G-27 (5") Bud Light (V. Keown)
G-28 (2 1/4") ANHEUSER (V. Keown)
G-29 (3 1/4") Coors (A. Santen)
I-28 (3 9/16") Budweiser (L. Biehl)
K-12 (7 3/4") Blatz (J. Ruckstuhl)
L-9 (6 5/8") Budweiser (V. Keown)
M-84 (6 1/4") Neuweiler's (T. Zanghi)
M-85 (7 3/8") Eagle in A (A. Santen)
M-86 (6 1/4") Falstaff (J. Horn)
M-87 (Balantine) Three Ring Logo (V. Vollrath)
M-88 Blatz (V. Vollrath)
M-89 (2 7/8") Budweiser (A. Santen)
M-90 (3 1/2") Oldenberg [Reverse Side Twist Off Opener] (A. Santen)

N-64 (7") Horlacher Beer (T.Zanghi)
 N-65 (2 3/4") Budweiser (M.Benjamin)
 P-90 (4 5/8" Height) (3 11/16" Handle) Northern Brewery (V.Volrath)
 P-91 (5" Handle) Natural (V.Keown)
 P-92 (5 1/4") Oldenberg (A.Santen)
 P-93 (6 1/4") The Home Brewing Co., Indianapolis, IN/SA (F.Graff)
 P-94 (3 7/8") Broadway Products Corp./Mfgs. of Liquid Malt (B.Ennis)
 Q-13 (3") Oldenberg (A.Santen)
 Q-14 (3 3/8") Budweiser (V.Keown)
 Q-15 (4") Busch (A.Santen)
 Q-16 (3 1/8") Busch (H.Waldo)
 Q-17 (2 1/2") Miller Tab Lifter/Twist Off (E.Kaye)
 Q-18 (2 5/8") Bud (V.Keown)
 Q-19 (3 5/8") Michelob (O.Hibbeler)
 Q-20 (3 7/8") Budweiser (B.Vanvactor)
 Q-21 (3 1/4") Coors (J.Cardone)
 Q-22 (2 5/8") Budweiser (V.Keown)
 Q-23 (4 3/4") Schmidt (V.Keown)
 Q-24 (2 3/4") Griesedieck Bros. Can (R.Brunner)
 Q-25 (1 1/8") Budweiser (V.Keown)
 Q-26 (2 1/2") Stroh's (A.Santen)
 S-2 Pabst Blue Ribbon Beer (F.Graff)
 X-3 (2 3/4") JFO 9th Convention (L.Biehl)
 X-4 (2 1/2") JFO 11th Convention (H.Danziger/L.Roe)

TO UPDATE YOUR NUMERICAL CHART OF OPENER TYPES (REF: JFO 42 APRIL 1989 PG. 12)
 CHANGE COLUMN 41 TO 44 AND ADD N.D. NUMBERS TO THE PROPER LINES

CORRECTION TO THE NUMERICAL CHART OF OPENER TYPES
 UNDER COLUMN 30, LINE X, ADD 2 (PICTURE IN JFO 27 PAGE 7)



B-62

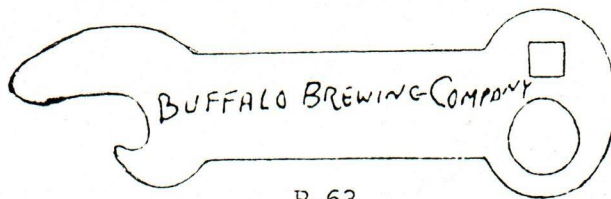

B-63

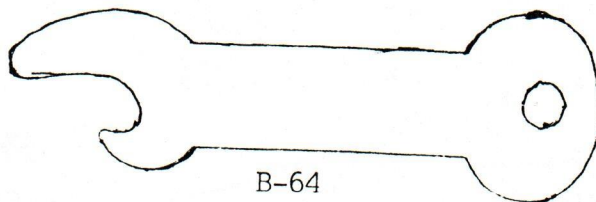

B-64



B-65



G-27



B-67

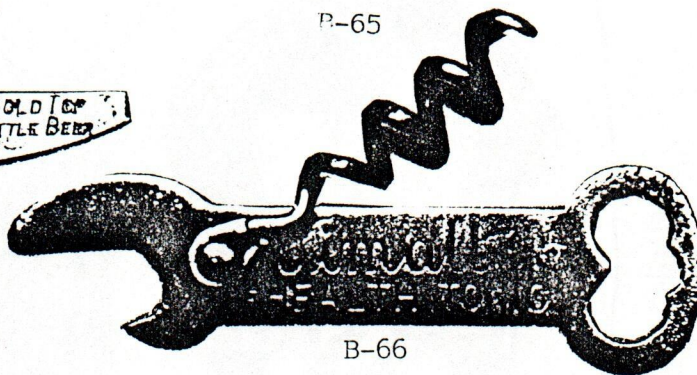

B-66

NOT ACTUAL SIZE

NOT ACTUAL SIZE



C-40

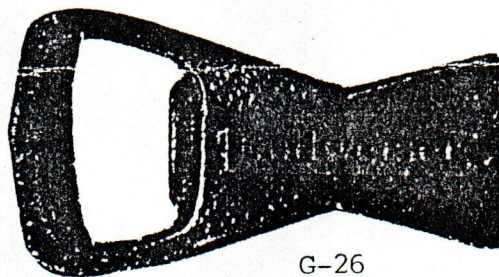

G-26



G-28

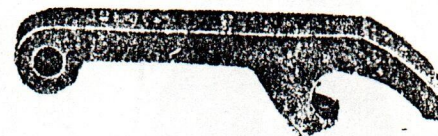

G-29

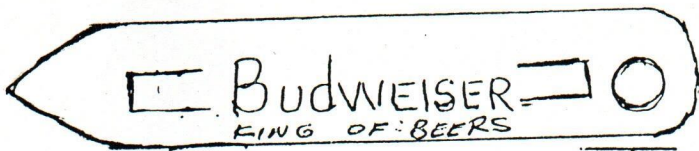

Flip Side, SAME WORDING.

5/8"

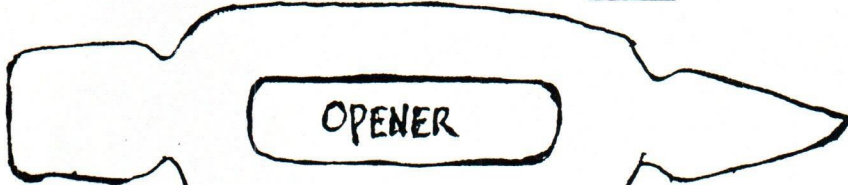
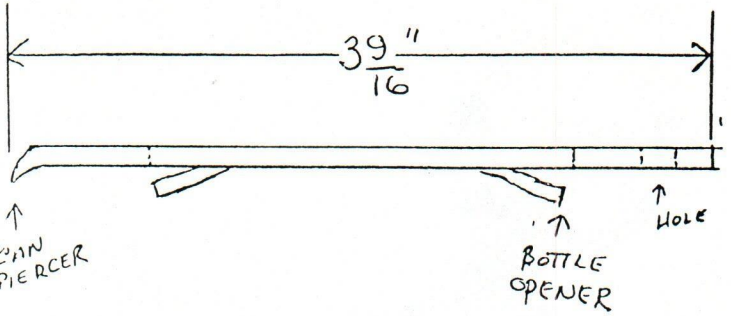

M-84



L-9

NEUWEILER'S ALE AND BEER

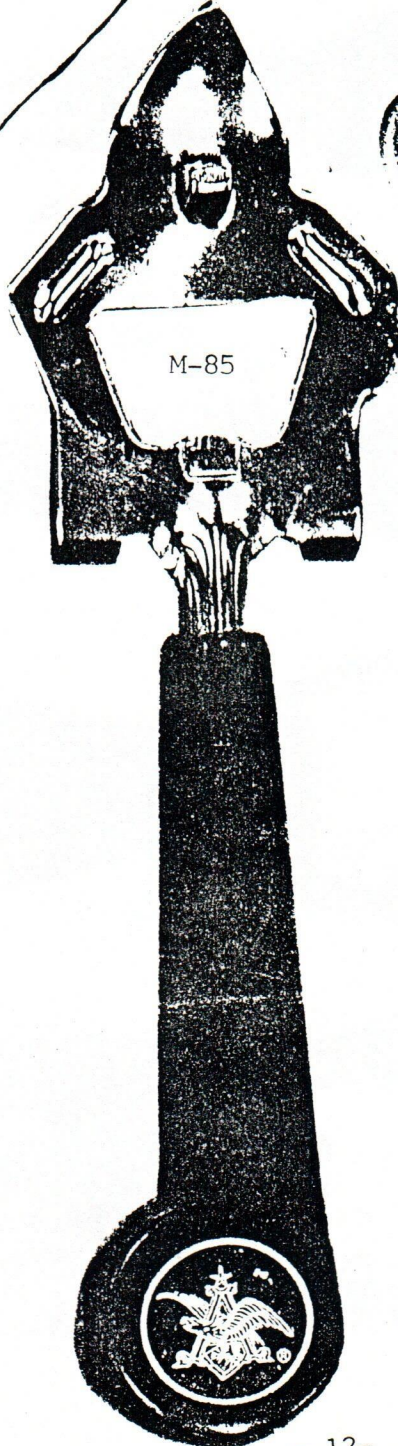

M-85



M-86

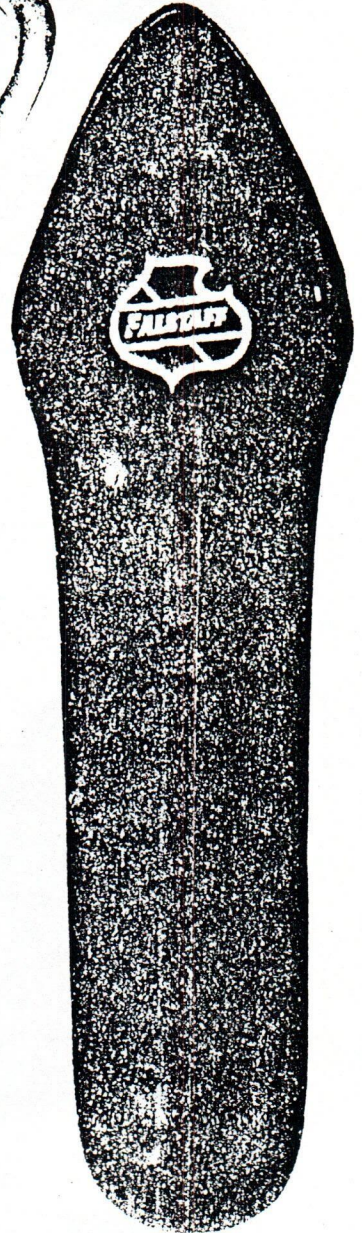

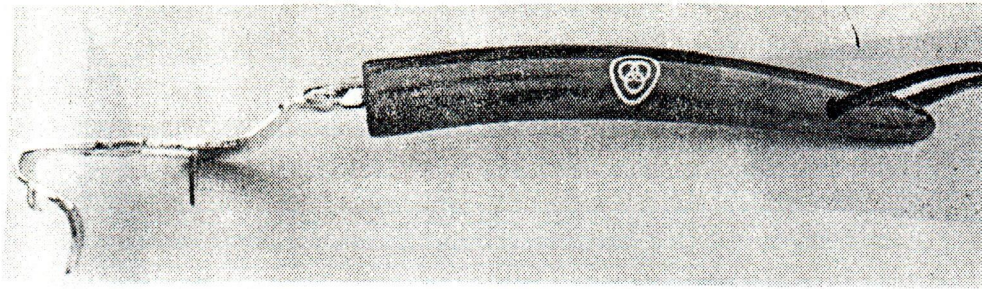

M-87

NOT ACTUAL SIZE

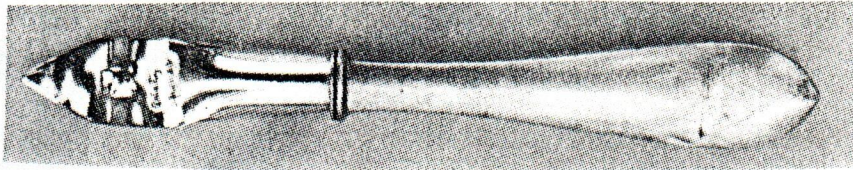

M-88

NOT ACTUAL SIZE

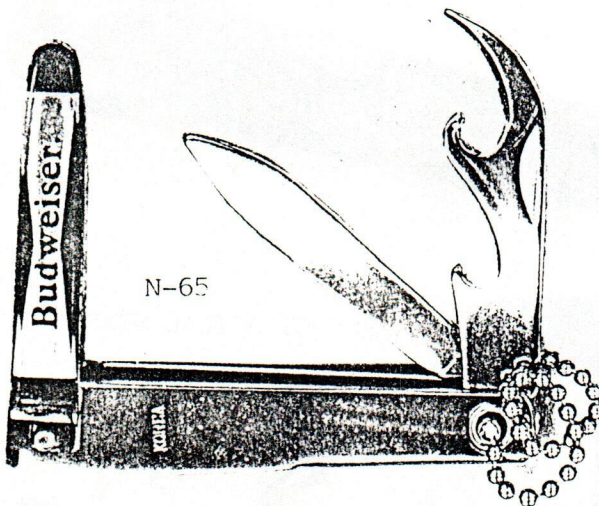

N-65



M-89

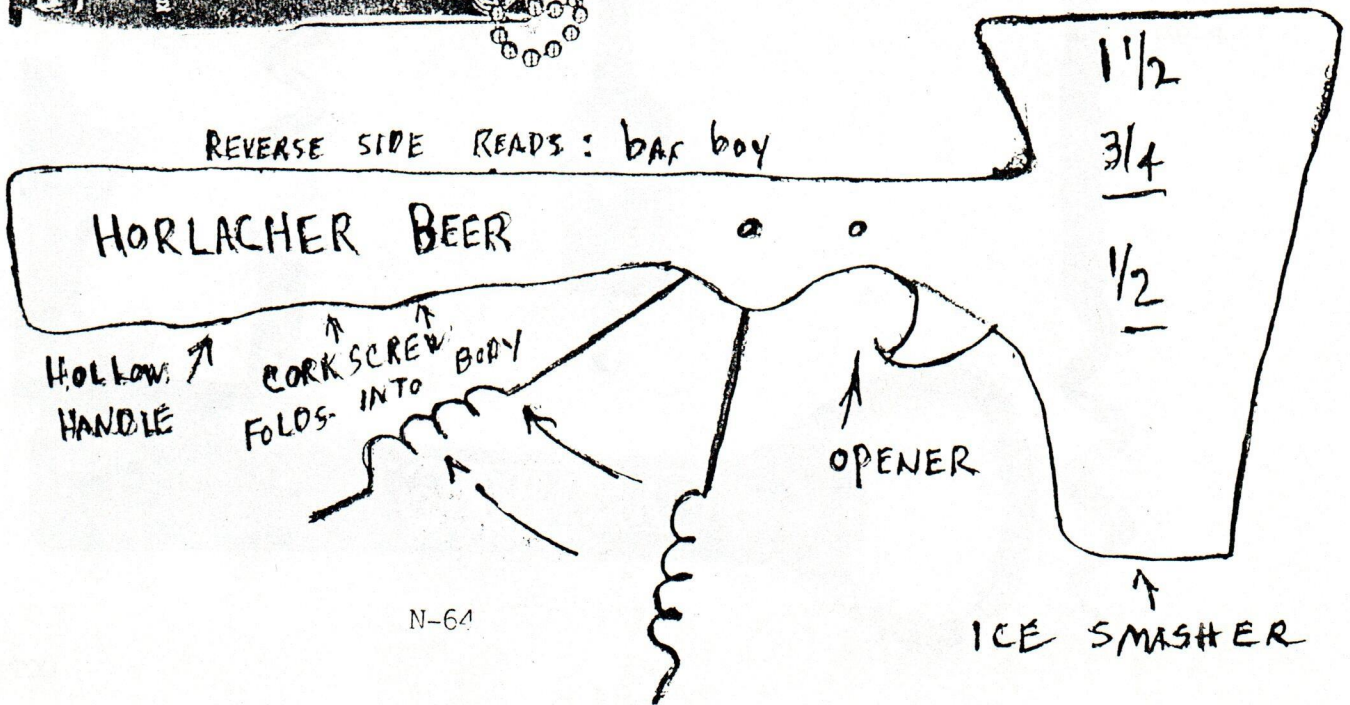

N-64



P-90

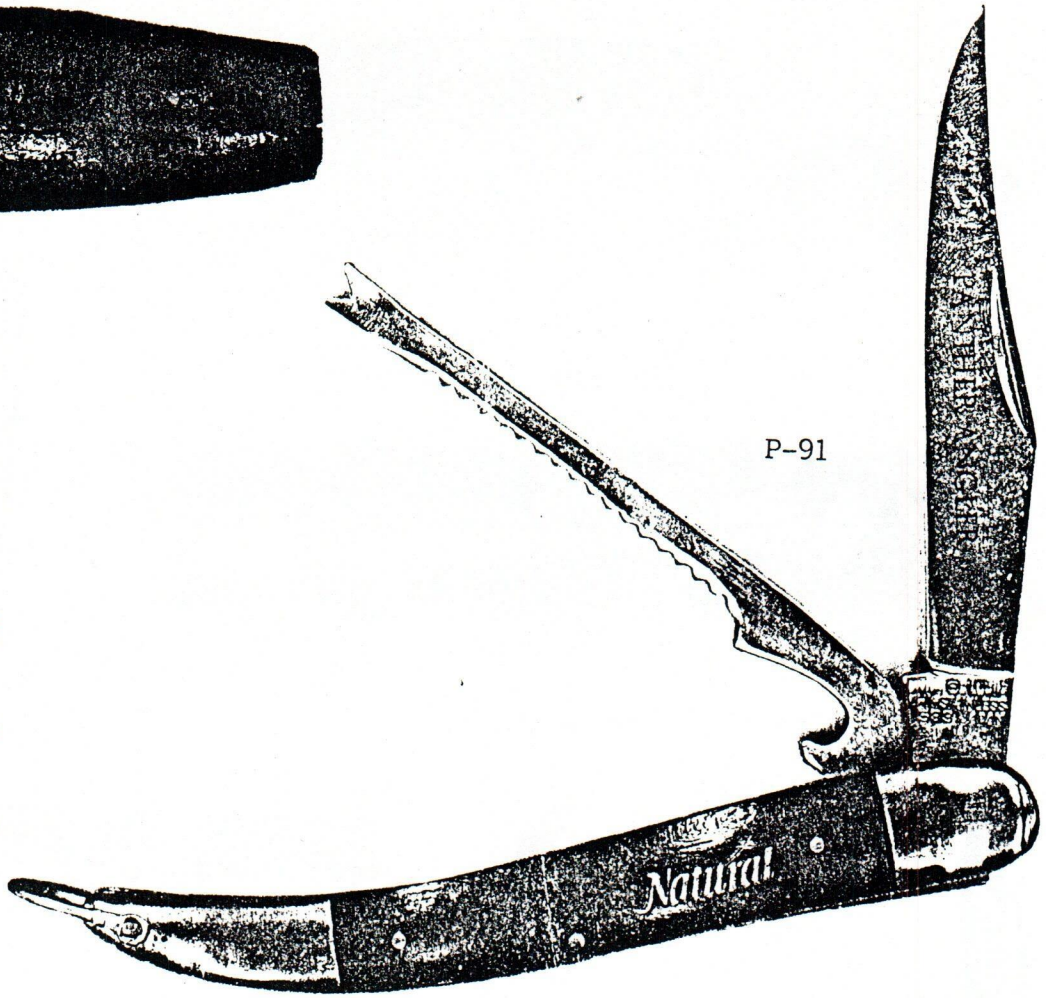

P-91

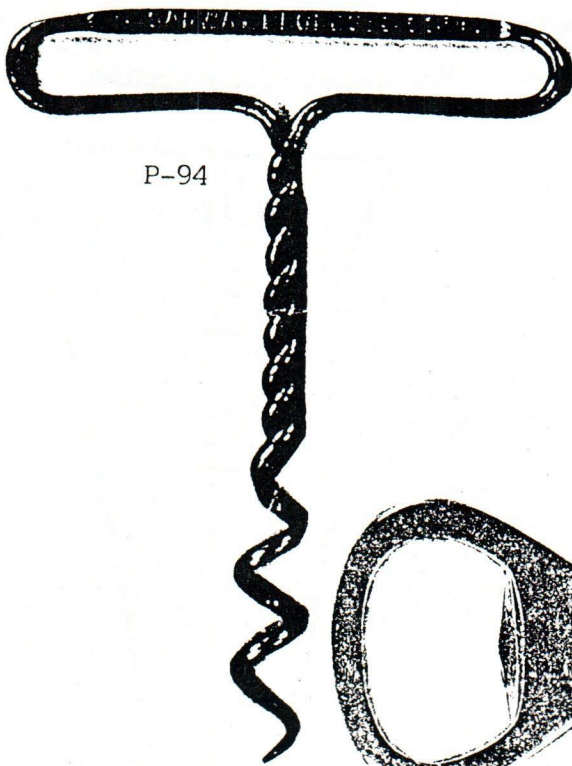

P-94



P-93 NOT ACTUAL SIZE

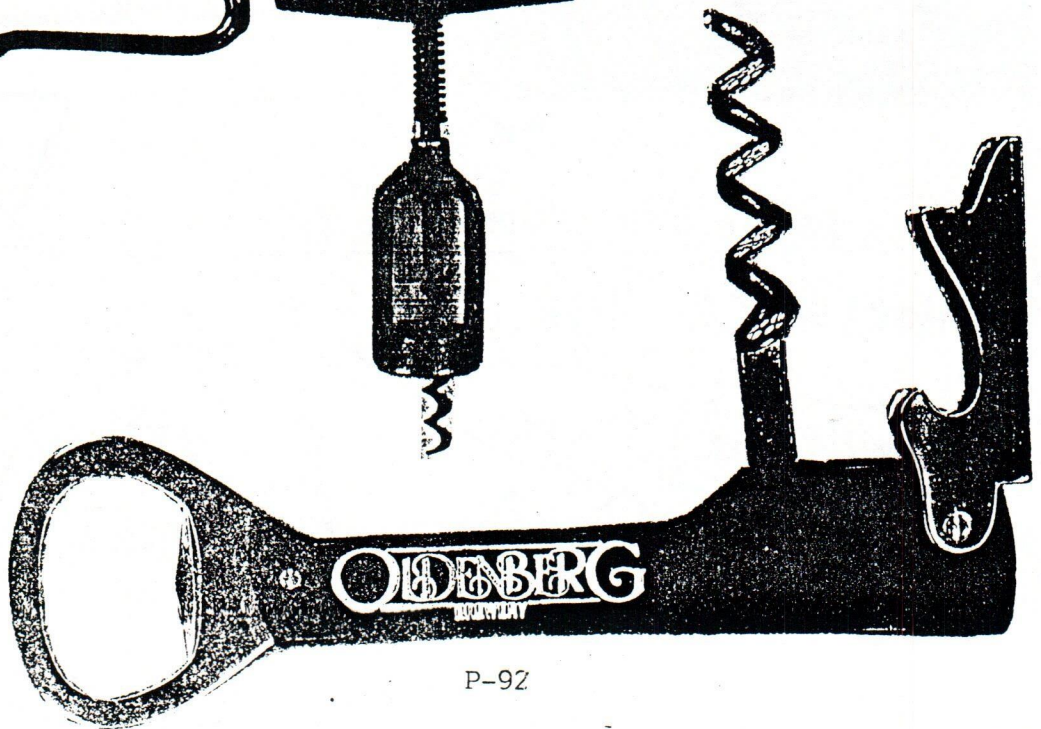

P-92

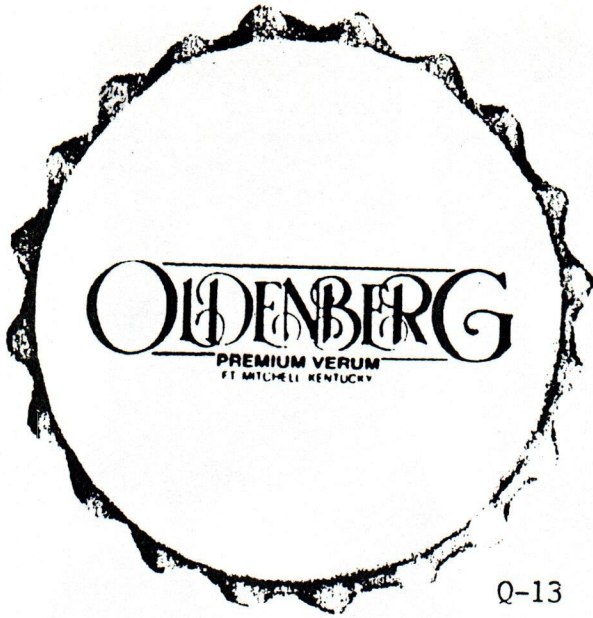

Q-13

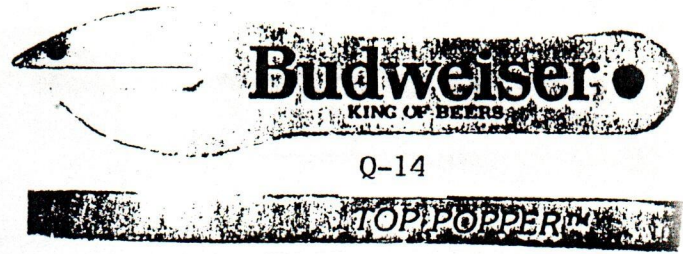

Q-14



Q-15



Q-16

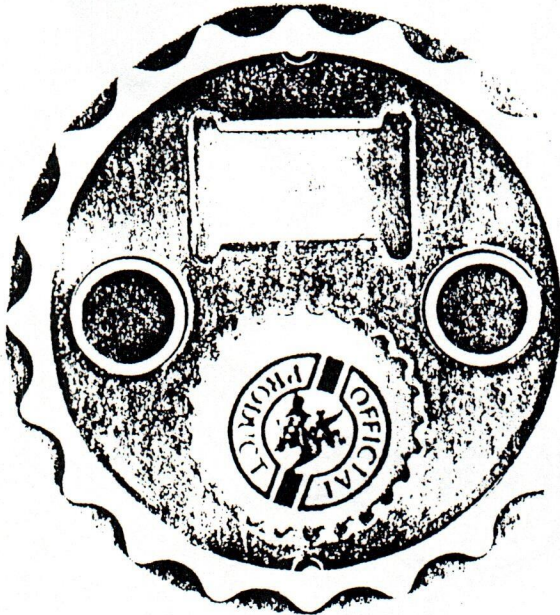

Q-13- REV-A

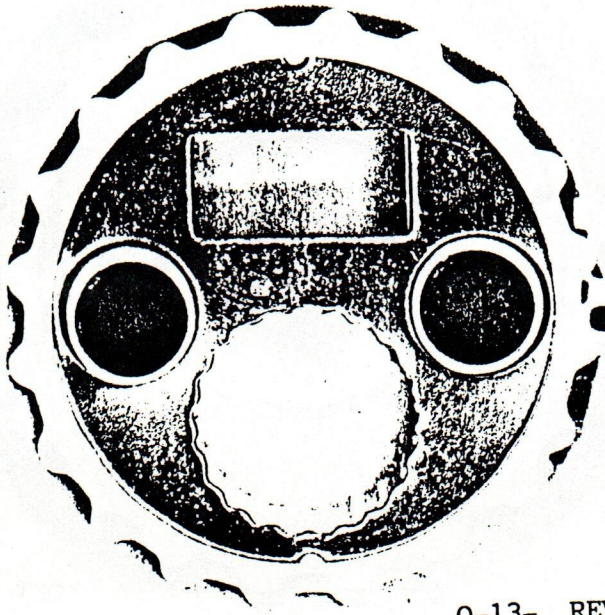

Q-13- REV-B



Q-17





Q-18

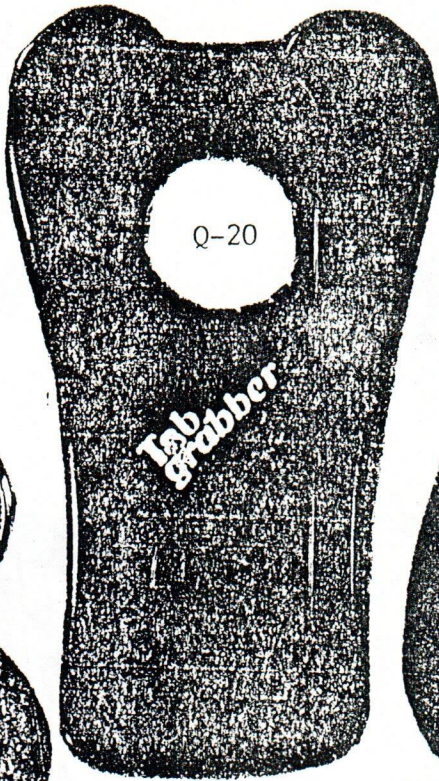

Q-20

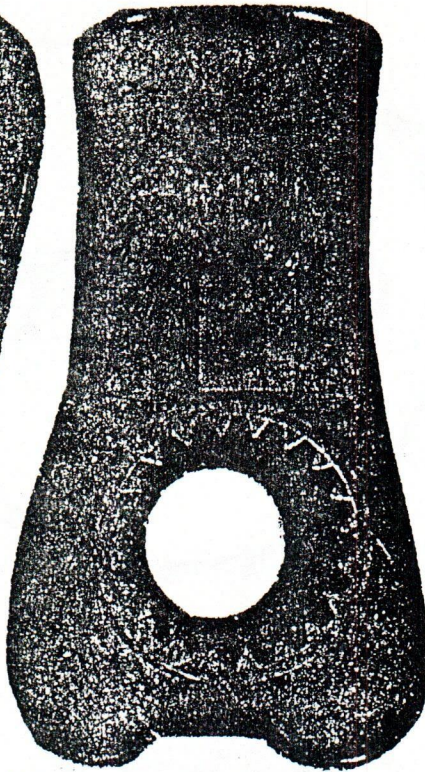

Q-19

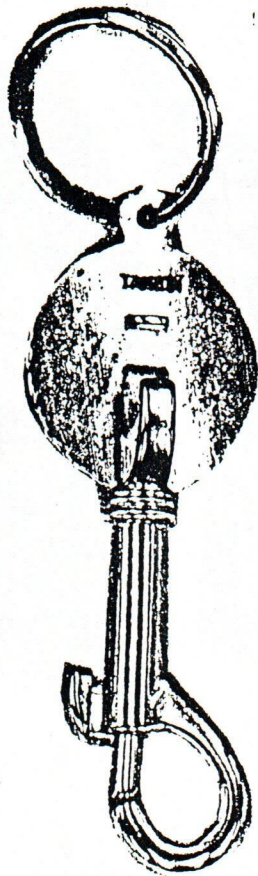

Q-22

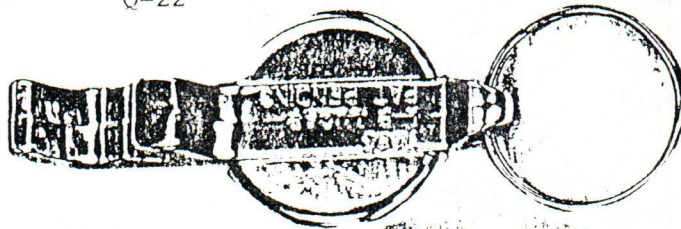

Q-21

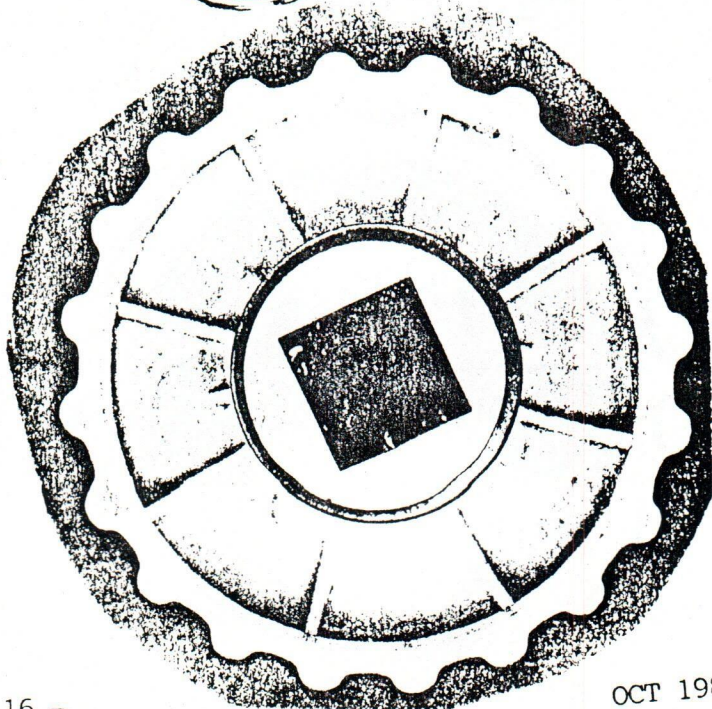

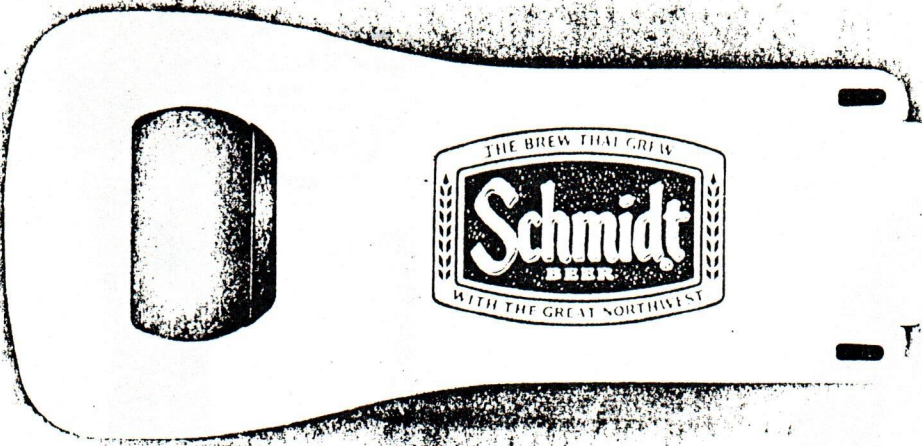

Q-23

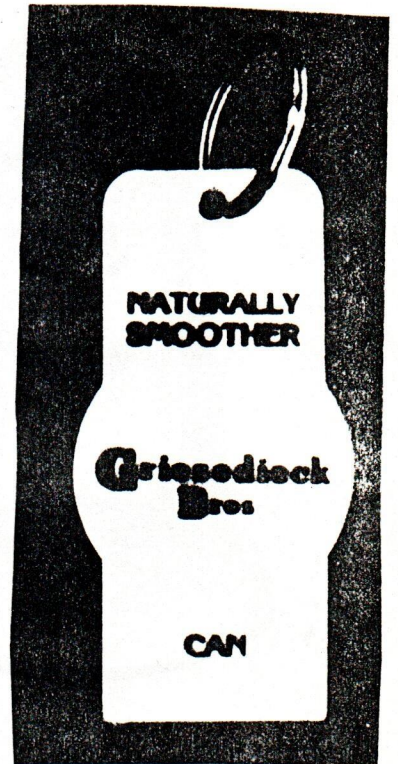
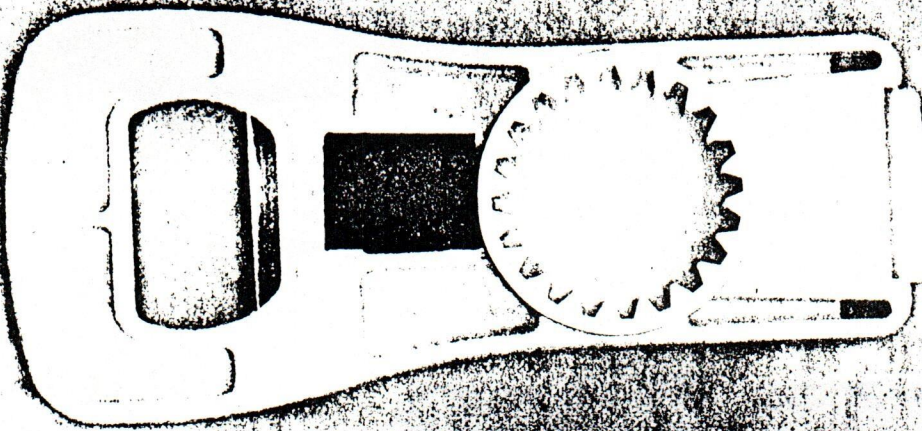

Q-24



Q-26



Q-25

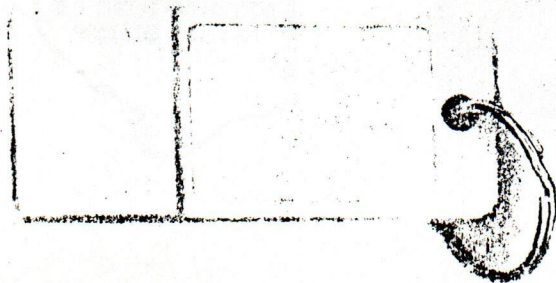



K-12



NOT ACTUAL SIZE

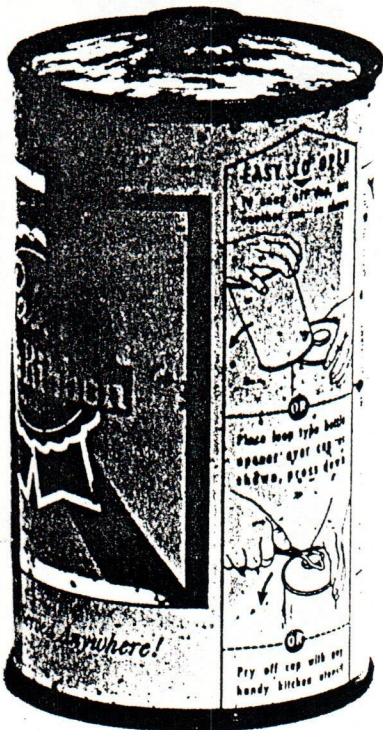

S-2

NOT ACTUAL SIZE



X-3

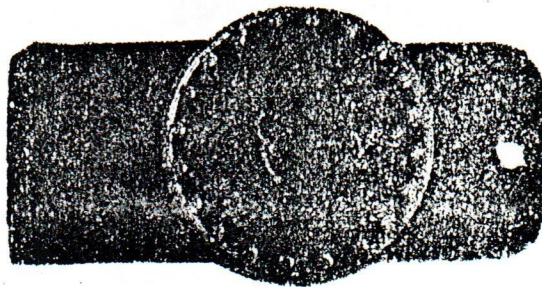

X-4