

# Just For Openers January-December 2025 1

## Trios of Patents Results In Handi-Opener & Pry-A-Lid By Don Thornton

It took three patents to get this kitchen marvel to the marketplace. Emile G. Boucher of Baltimore was awarded patents in 1950 for what he called (1) a “jar and tumbler cap lifting and removing tool,” (2) a “pry type jar cap remover,” and (3) a “removing tool for vacuum jar caps.” Despite the different patent descriptions it was basically the same tool designed to open vacuum-sealed jars and bottles.

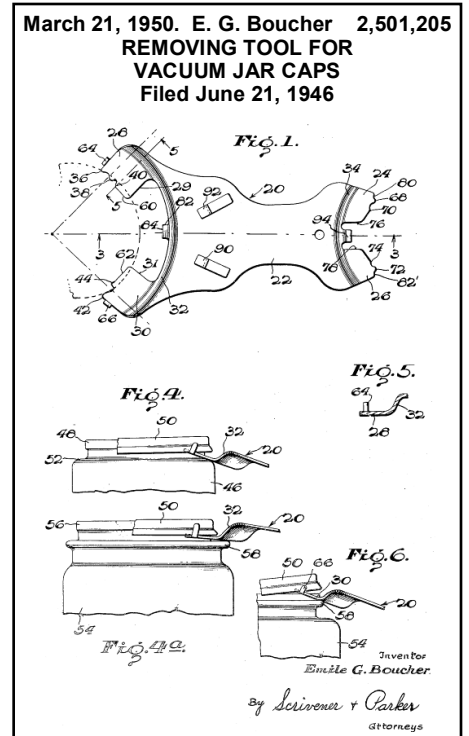
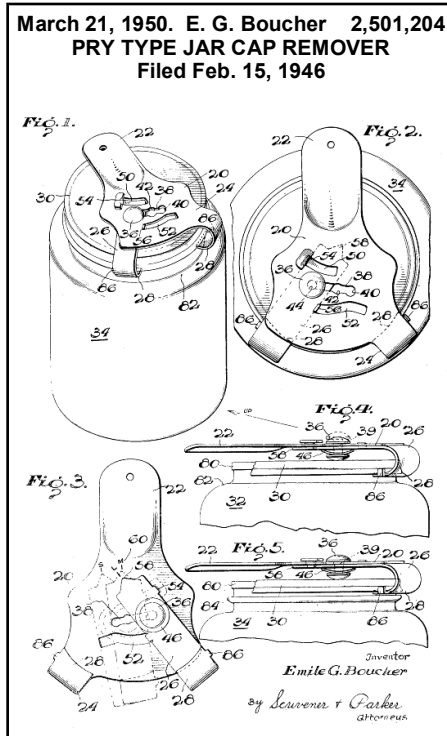
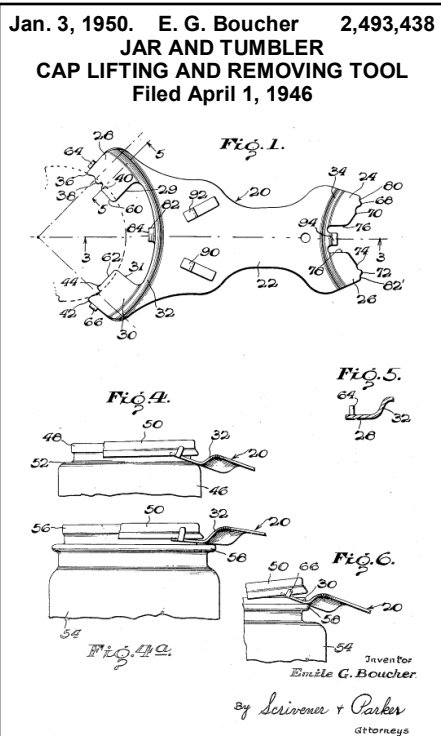

“The principal object of the present invention is to provide a novel unitary tool which is capable of quickly removing caps and lids from jars, bottles, tumblers and other types of glass containers of various sizes, without marring or bending cap or lid and without chipping or cracking the container,” Boucher said in his patent application. A cap that has not been bent can be easily re-sealed to the glass container, solving a then major problem, he said.

Although Boucher was awarded three patents, not one of them featured a cut out crown cap remover on the handle – something the manufacturers added to the 5 ½-inch device with two arms. The first manufacturer is believed to be the Washburn Company of Worcester, Massachusetts, which carried the Androck line of kitchen and other products. An example of the opener is marked: **ANDROCK MADE IN U.S.A. PATENTS APPLD FOR.** It is also marked with instructions:

**GLASS TUMBLERS ARMS ON TOP AND LIFT UP**  
**ALL OTHER JARS ARMS UNDER COVER AND PUSH DOWN**  
**COFFEE JARS LIFT UP**



## Trios of Patents Results In Handi-Opener & Pry-A-Lid By Don Thornton

The next manufacturer was the famous branding company Brown & Bigelow of St. Paul, Minnesota. One branded opener is marked on top: **NO DONUTS LIKE DIXIE CREAM DONUTS** and on the end: **PATENTS 2,493,438 2,501,204 2,501,205 CANADA 474,876 475,060**. It is also marked in very small type: **B&B ST. PAUL MINN. U.S.A. REMEMBRANCE**.



B&B marketed its opener as the “HANDI-OPENER JAR-TUMBLER-BOTTLE TOP REMOVER.” It was packaged in a heavy paper envelope with instructions and drawings. One “handi-opener” was branded: **HOLMES & GARNETT HARDWARE - TOYS - SPORTING GOODS - PLUMBING - HEATING - SOFTENER SERVICE PHONE. 571 MILTON, WIS.** It also is marked on the end of the handle the same as the Dixie opener.



Household Wares Inc., a short-lived Baltimore company that said it employed chiefly handicapped persons, later marketed the tool as the **PRY-A-LID**, with a colorful yellow and red cardboard backing to attract retail sales. It wasn’t offered for branding and instead was marked: **PRY-A-LID HOUSEHOLD WARES INC. BALTIMORE, MD MADE IN U.S.A. PATENTED**.

Boucher’s invention career was limited to the three opener patents — but they were long-winded — running seven, eight and 13 pages long.

**Gettelman Brewing and Richbrau Beer Advertising Boucher Patented Openers next page.**

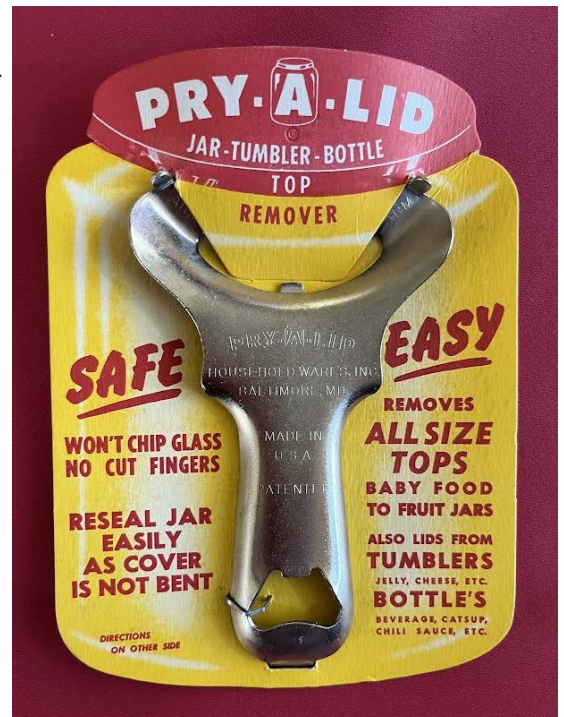

# Just For Openers January-December 2025 3

## Trios of Patents Results In

Handi-Opener & Pry-A-Lid By Don Thornton



**handi-opener**  
JAR-TUMBLER-BOTTLE TOP REMOVER



Tops of all sizes — from baby food to fruit jars — are safely and easily removed with the Handi-Opener. And they reseal conveniently since they are not bent in opening. No more chipped glass or cut fingers.

**★ PRESS-ON-JARS** — Put "arms" of opener under top, push handle up or down.

**★ BEVERAGES**—Turn opener over, place opening in handle on top of cap, hook below, raise up.

**★ BOTTLES**—On catsup, chili sauce, etc., put end of handle under top and twist.

**★ TUMBLERS**—Put "arms" on top, place hook (centered between "arms") below cap, lift up.

**★ RESEALING** — Covers, not bent in opening, reseal easily with firm pressure from "heel" of hand.

**PRESS-ON-JARS**



**BEVERAGES**



**BOTTLES**



**TUMBLERS**



**RESEALING**

**New! VACUUM CAP OPENER** FOR ALL JARS GLASSES, BOTTLES  
Open any vacuum-sealed container with

*Quick lever action!*



**Safe - Re-seal -** WON'T CHIP GLASS NO CUT FINGERS  
COVER IS NOT DISTURBED CAN BE EASILY RESEALED

**ANDROCK**  
PAT. APPL. FOR

**DIRECTIONS FOR USE:** ON THE BACK OF THE CARD

**JARS:** Baby Food, Coffee, Fruit, Vegetable, Jam

**TUMBLERS:** Chocolate, Juice

**CANS:** Beans, Canned Fruit, Honey, Syrup