

Just For Openers January-December 2025 1

John Nagy & Wilbert Jones

Two-Ways To Six-Ways By Don Thornton

It took two patents but John Nagy and Wilbert James finally put it all together. The New York City inventors were granted Patent No. 2,741,835 on April 17, 1956 for a “can opener.” Four years later, they were obtained Patent No. 2,964,763 dated December 20, 1960, for a “combined can punch and cap remover.”

If the first patent had made it to the market place, it would have been branded the “2-Way Opener” for its church key and bottle opener combo. The second patent did make it to the market and it was branded the “6-Way Opener.”

It was a combined church key with two-hole punch, bottle opener, vacuum seal lid lifter for jars, vacuum seal lifter for bottles and a seal cutter. And, according to the patent papers, it was “novelty designed in such a manner as to result in increased leverage during the operation of forming dispensing and vent openings in the container.”

The opener was produced by the Vaughan Manufacturing Company of Chicago, thus the Vaughan name. It re-tailed for 29 cents, according to a 1962 grocery store ad. The two patents were assigned to King Kan Opener, Inc. of New York City, for which there is no record, but ended up the property of Vaughan.

It should be noted the 1960 patent took the opportunity to state a decades old fact about the opening tool industry: An object of the invention is “to provide a tool of this kind which can be fashioned from relatively

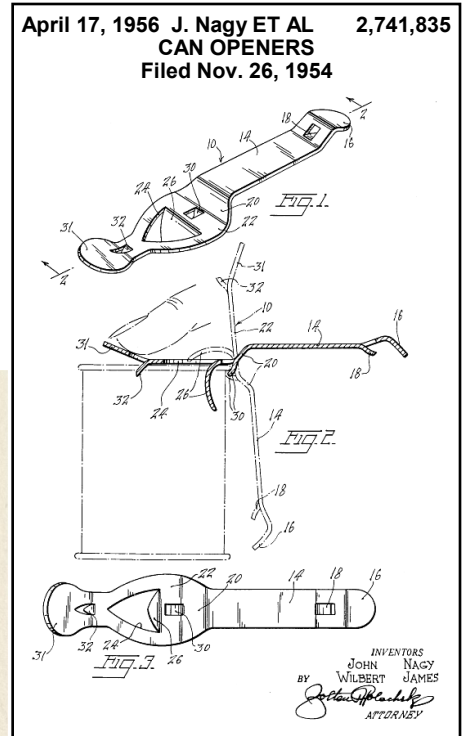

The 5 1/4-inch opener is marked:
VAUGHAN 6-WAY OPENER PAT. NOS. 2,741,835 2,964,763 CHICAGO 24 U.S.A.



Just For Openers January-December 2025 2

John Nagy & Wilbert Jones

Two-Ways To Six-Ways By Don Thornton

thin sheet metal material, thus holding the cost down to the maximum extent. This is particularly important in view of the fact that opening tools of this type are generally distributed complementarily to purchasers of the beer or other beverages sold in the can."

New Can Can 6-Way Opener 29¢

Opens cans, jars, bottles, boxes, seals, lids, punches holes, cuts seals, etc.

SIDEBAR: Wilbert James was awarded another kitchen patent that caught the eye of the *New York Times*. Patent No. 3,354,922 dated November 28, 1967, was granted to James for his "fumeproof, transparent enclosure for preparing onions."

The *Times* in a "Focus on Patents" column in December, 1967, said: Wilbert James of New York was granted a patent this week for a transparent plastic bag inside which the housewife can peel onions without crying. Her hands, an onion and a knife can be inserted through a pair of tubular plastic mittens. The device is called ONIONMASTER." James even obtained a trademark for the ONIONMASTER name in 1967 but there is no evidence the "fumeproof" enclosure made it to the market place.

Dec. 20, 1960 J. Nagy ET AL 2,964,763
COMBINED CAN PUNCH AND CAP REMOVER
Filed Dec. 1, 1958 Sheet 1

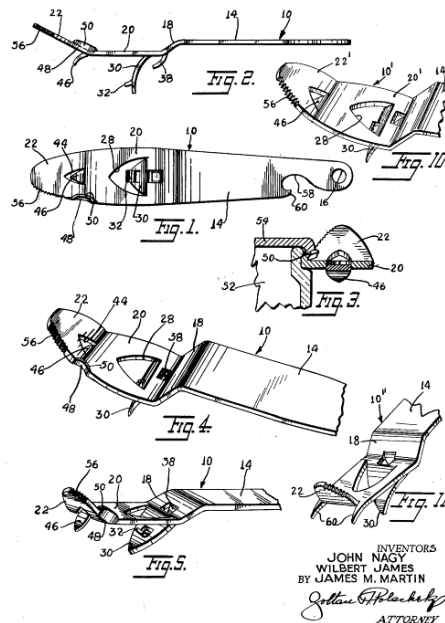

Dec. 20, 1960 J. Nagy ET AL 2,964,763
COMBINED CAN PUNCH AND CAP REMOVER
Filed Dec. 1, 1958 Sheet 2

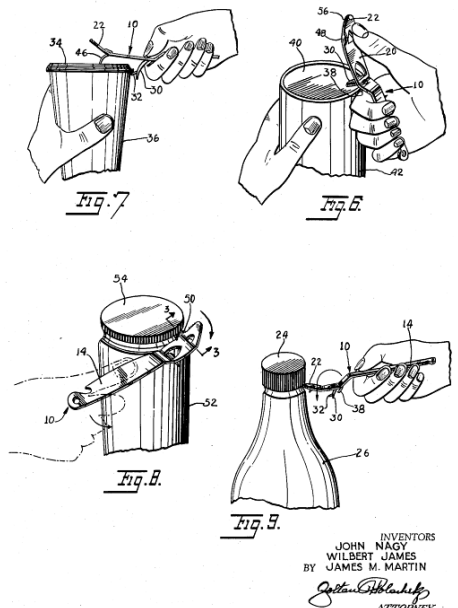

Nov. 27, 1967 W. James 3,354,922
FUMEPROOF, TRANSPARENT ENCLOSURE
FOR PREPARING ONIONS
Filed July 14, 1965 Sheet 1

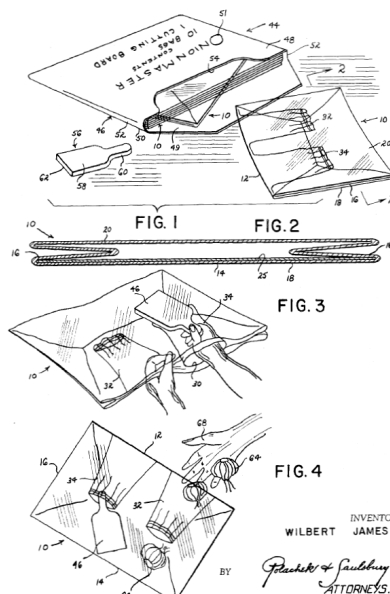

Nov. 27, 1967 W. James 3,354,922
FUMEPROOF, TRANSPARENT ENCLOSURE
FOR PREPARING ONIONS
Filed July 14, 1965 Sheet 2

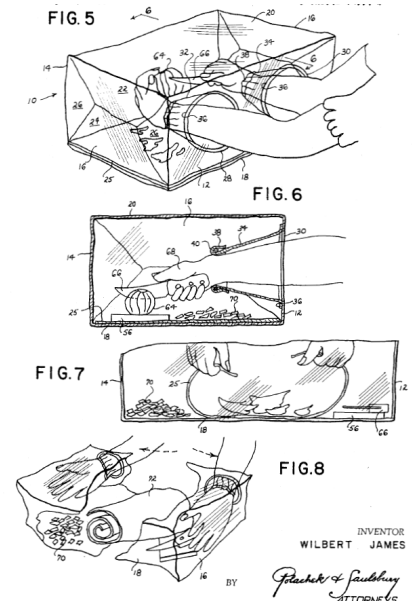

Wordmark ONION MASTER, Status DEAD, Goods & Services [FUMEPROOF, TRANSPARENT PLASTIC BAGS FOR PEELING, SLICING], Class 017, Serial 72226644, Owners WILBERT JAMES (UNKNOWN; Not In List)