

Just For Openers January-December 2025 1

Locke's Pop'N Stop With Push Button Cap Release By Don Thornton

C. Joseph Locke was a sailor, police detective, private eye, land developer and an inventor, among other things. Unfortunately, despite his other career successes, his invention was a fizzle. Locke, a resident of Lake Oswego, Oregon, was awarded Patent No. 4,403,528 September 13, 1983 for his "crown cap removing and retaining implement" which he branded the **POP'N STOP**.

Locke said in his patent papers his invention was "an improved device for removing a crown cap from a bottle, retaining it in the device and subsequently resealing the cap on the bottle or releasing the cap for discard" with a special spring "push button." The heavy duty plastic and chrome device is 6 1/2-inches long and marked on the top cup above the release button: **POP'N STOP U.S.A. PAT.PEND.**

Locke's L-N International Inc. of Lake Oswego trademarked the POP'N STOP name and began production before the patent was granted. As far as can be determined Locke's only advertising was exploratory. The same display ad was taken out on June 13, 1982 in the *Houston Post*, *Lincoln Star Journal* in Nebraska, and the *Daily Breeze* in Torrance, California.



United States Patent [19] [11] **4,403,528**
 Locke [45] **Sep. 13, 1983**

[54] **CROWN CAP REMOVING AND RETAINING IMPLEMENT**
 [75] Inventor: C. Joseph Locke, Lake Oswego, Oreg.
 [73] Assignee: L-N International, Inc., Lake Oswego, Oreg.
 [21] Appl. No.: 278,042
 [22] Filed: Jun. 29, 1981
 [51] Int. Cl.³ B67B 7/16; B67B 7/44
 [52] U.S. Cl. 81/3.46 R; 81/3.1 C
 [58] Field of Search 81/3.1 R, 3.1 B, 3.1 D, 81/3.1 C, 3.46 R, 125

Primary Examiner—Roscoe V. Parker
 Attorney, Agent, or Firm—Kolisch, Hartwell & Dickinson

[57] **ABSTRACT**
 An improved device for removing a crown cap from a bottle, retaining it in the device and subsequently reseating the cap on the bottle or releasing the cap for discard. Included is a rigid body having an elongate handle joined to a head formed with a cavity for receipt of a crown cap attached to a bottle. The head has an opening opposite the handle for engaging the rim of a cap during removal. An elongate leaf-spring member has an expanse substantially parallel to the handle with one end fixed to the handle. A distal end extends at an obtuse angle into the cavity. It terminates in a reverse bend away from the cavity. A push button attached to the member intermediate its ends extends through an opening in the handle for manually releasing a retained cap.

[56] **References Cited**
U.S. PATENT DOCUMENTS
 Re. 23,731 11/1953 Belpedio 81/3.1 D
 2,641,397 6/1953 Sander 81/3.1 C
 2,801,557 8/1957 Belpedio 81/3.1 C

3 Claims, 5 Drawing Figures

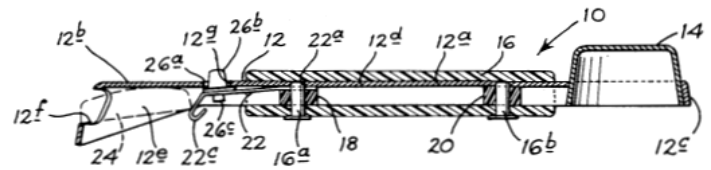

U.S. Patent Sep. 13, 1983 4,403,528

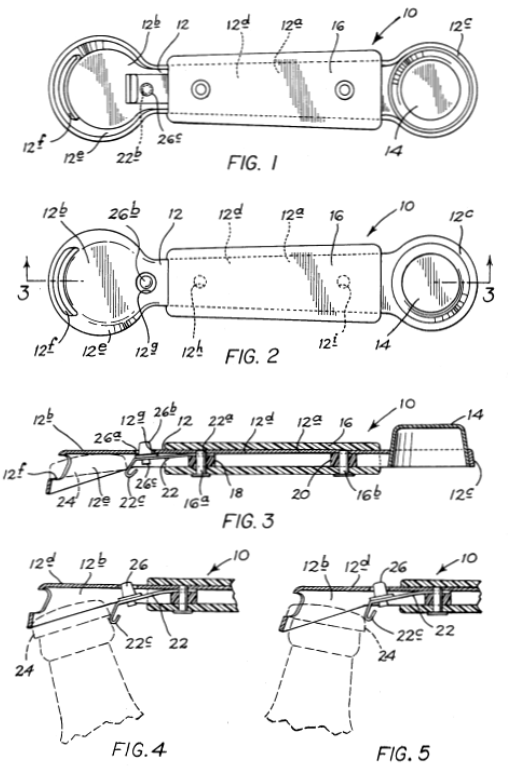

Just For Openers January-December 2025 2

Locke's Pop'n Stop With Push Button Cap Release By Don Thornton

The ad said in part: "Pop'n Stop is the easy to use kitchen and bar accessory. One end opens capped bottles, and the other tightly reseals." It also offered an "Unconditional Guarantee" that "if you're not absolutely delighted, your money will be refunded and we'll send along an extra dollar for your effort!" The price: \$6.50 each for two or more, or one for \$6.95.

The ads apparently bombed. No others appeared. However, production continued, at least for a while, based on the number of the devices that appear for sale on the Internet.

Locke died in 1999 at the age of 68. The Portland, Oregon *Oregonian* reported in his obituary that Locke "was in the merchant marine as a young man and served in the U.S. Army military police from 1951 to 1959. He was a detective in the San Pablo, Calif., police department for about six years, then had a private detective agency in California before moving to Portland in 1968. He was a land developer in Boardman and then Hawaii, and was a political consultant, mostly in Hawaii." His invention was not mentioned.

POP'N STOP

Wordmark [POP'N STOP](#)

Status **DEAD** **CANCELLED**

Goods & services (CANCELLED) IC 008: [Hand Implement for Removing a Cap and Remounting...

Class 008

Serial 73279308

Owners L-N International, Inc. (CORPORATION; OREGON, USA)



Patent Pending

GUARANTEED...

Remarkable New Product Saves You Time and Money...Elegantly

This durable, good looking beverage opener will reseal using the original cap!

Pop'n Stop™ is the easy to use kitchen and bar accessory. One end opens capped bottles, and the other tightly reseals. The crimp is actually put back on the cap. Beverages stay fresh. You won't use inconvenient stoppers again. Here's what some of our customers say:

"Your Pop'n Stop™ opener is the greatest!"
 "This is what I've been waiting for!"
 "We've been using one for a month"

now and they are great!
 Now need some for gifts!"

You'll enjoy owning one. They're unique, effective, inexpensive and American made. The heavy chrome on steel finish, earth toned sturdy handle and push button cap release were designed for a lifetime of trouble free service.

The Unconditional Guarantee says if you're not absolutely delighted, your money will be refunded and we'll send along an extra dollar for your effort! Fill in the coupon now! Use check, money order, or credit card. They're only \$6.50 each for two or more, or \$6.95 for one. We pay shipping costs. Orders are filled on a first come basis, so the sooner yours is received, the sooner you can enjoy the quality, style and convenience of Pop'n Stop.™

(Special Limited Offer)

Yes, send me _____ Pop'n Stop™ at only \$6.50 each for two or more, or one for \$6.95.

Check Money order VISA MC

Name _____

Address _____

City _____

State _____ Zip _____

Card No. _____

Expiration Date _____ Signature _____

Pop'n stop
 A Product of L-N International
 15806 S.W. Upper Boones Ferry Rd.
 P.O. Box 1868 Dept. P1
 Lake Oswego, Oregon 97034

Pop'n stop

Amazing new bar tool opens and reseals bottle with original cap.

Keeps soda, beer fresh & bubbly. Forget ineffective plugs & stoppers

Patent Pending

TO OPEN:
 Place OPENER END over cap. Opener should be flat on cap. Press downward to open. Cap will remain in opener. If not resealing, press button to discard cap.

TO RESEAL:
 Place OPENER END with cap back on bottle, press down to reset. Place RESEALER END over cap, press down firmly with palm. Rotate 1/4 turn (crimping the cap.) Lift off tool. **Note:** after resealing do not shake or turn upside down as temporary seal could leak.