

Just For Openers January-December 2025 1

Stewart's E-Z Lift

Patent Journey By Don Thornton

Joseph A. Manarik of Chicago patented his pliers-like bottle and jar cap remover on Nov. 3, 1936, Patent No. 2,059,736. However it sat idle until 1946 and when it did come on the market, manufactured by Stewart Products Inc. of New York, it was a different beast. Bertram H. Stewart of New York City was the force behind the Stewart manufacturing concern. He apparently took a fancy to the reverse-pliers concept of the cap-lifting device – and this is where the patent story gets interesting.

Stewart applied for and was granted Design Patent No. 145,647 on September 24, 1946 for his own "jar and bottle cap remover" – and the **E-Z LIFT** was born, with the added attraction of a cut-out hook to remove crown caps from bottles.

The 5-inch device is marked: **PAT. NO. 2,059,776 E-Z-LIFT OTHER PATS PENDING** on the main arm, and around the end of that arm: **A STEWART PRODUCT MADE IN U.S.A.** The bottle opener arm is marked: **DIRECTIONS 1. INSERT TIP IN SPACE BETWEEN CAP AND JAR 2. PUSH FORWARD LIGHTLY AND SQUEEZE TO REMOVE TOP.**

Nov. 3, 1936. J. A. Manarik 2,059,736
BOTTLE CAP REMOVER
 Filed Jan. 18, 1936

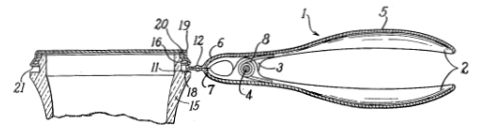

Fig. 1

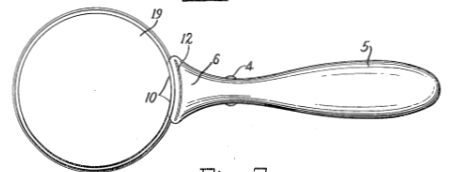

Fig. 2

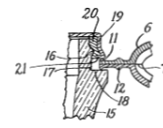

Fig. 3

—Inventor—
 Joseph A. Manarik
 By Morris Spector
 Attorney

Sept. 24, 1946. B. H. Stewart Des. 145,647
JAR AND BOTTLE CAP REMOVER
 Filed Nov. 29, 1945

Fig. 1

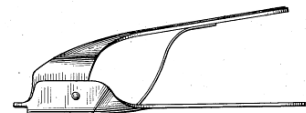

Fig. 2



Fig. 3



Fig. 4



INVENTOR.
 Bertram H. Stewart
 BY Moxa & Allen
 ATTORNEYS



Just For Openers January-December 2025 2

Stewart's E-Z Lift Patent Journey By Don Thornton

Despite having Manarik's patent number, the tool matches Stewart's design patent perfectly, including the bottle opener. Why did Stewart give Manarik credit instead of his design patent? The two men obviously had a deal. And the fear of infringement of the pliers concept probably played a role.

Newspaper ads for the E-Z LIFT began in 1946. For instance, the following appeared in the *Brooklyn Daily Eagle* on November 21 of that year: "At long last, some one has given thought to a cap-lifter which not only removes the tops from jars and bottles efficiently but leaves them whole and perfect for recapping the food container if necessary. E-Z cap lifter, the latest creation of Stewart Products, Inc. may be used to open food and candy tins, paint cans and all those vacuum capped bottles and jars which are usually opened with a struggle and the back of a knife." Another newspaper ad said in part: "A Gentle Squeeze Pops the Caps Off."

E-Z-LIFT
cap-lifter
SOLD EVERYWHERE

Guaranteed by
Good Housekeeping
if defective or
not as advertised therein

A GENTLE SQUEEZE
POPS THE CAPS OFF
VACUUM JARS
PAINT AND CANDY TINS
—and does not bend the caps!
ALSO LOOSENS
ICE CUBE TRAYS

STEWART PRODUCTS, INC.
NEW YORK 14, N. Y.

Stewart followed his design patent up five years later when he applied for and was granted Patent No. 2,570,881 on October 9, 1951 for his "plier type friction-cap remover." Coincidentally, only months later, ads appeared in newspapers describing the E-Z Lift as new to the market, the latest kitchen device for the housewife.

For example, this testimonial appeared in the *Orlando Sentinel* July 28, 1952: "As necessary as a can opener... as handy as a bottle opener... That's the advertised description of one of the newest kitchen gadgets on the market. Many a housewife will welcome the introduction of the E-

Z Lift cap lifter... The E-Z Lift is not just another opener. A gentle squeeze, and off pops any anchor type friction cap, any size."

Stewart's 1951 patent probably prompted the "newest" gadget label promotion, but the tool remained the same, with Manarik's patent number, according to newspaper ads over the years. Advertisements appeared, off and on, from the 1940s to 1961 (on sale for 10 cents).

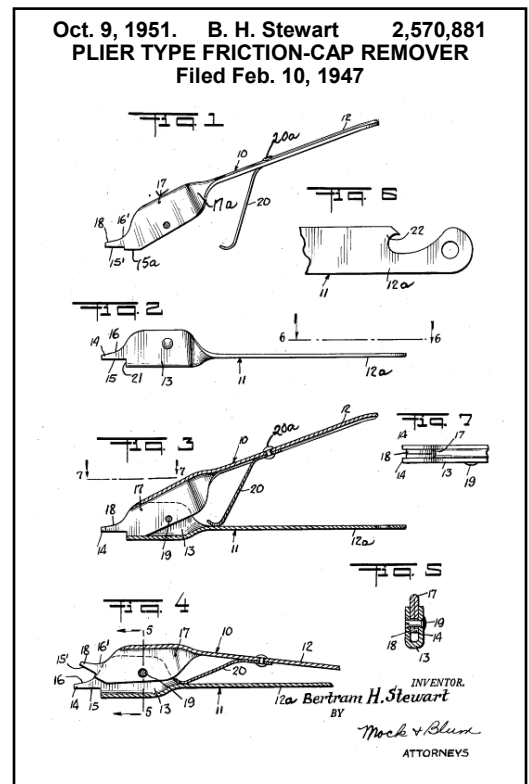

Stewart's E-Z Lift

Patent Journey By Don Thornton



There is another twist to the E-Z Lift story. Josef L'African, noted corkscrew collector and historian, reported the discovery of an E-Z Lift corkscrew on his Josef@vintagecorkscrews.com in 2012. He described it as a simple folding corkscrew marked **E-Z LIFT A STEWART PRODUCT MADE IN U.S.A.**, just like the jar lifter. Background on the opener with worm is sketchy at best -- neither patent by Stewart nor a patent assigned to his company.

Asked recently for an update, L'African said: "I never have found anything further about the corkscrew, but I did find a second example, so they made more than one. I do find it fascinating that someone that has gone through the patent process wouldn't choose to patent the other items that they made."