

Just For Openers January-December 2025 1

Loeser Kalina: Vest Pocket Tool Czar

By Don Thornton

Loeser Kalina of New York City was a creative and prolific inventor, being granted at least a dozen patents from 1913 to 1934. They were a mixed lot, including garment hangers, safety razors, a combination tool, a folding toothbrush, a wrench, a percolator, a woman's garment, a paper envelope and a deadbolt door lock.

Of all the patents, two stand out as perfect examples of "vest pocket" tools. In the JFO world, the most popular of the two is a just under 2-inches in diameter "combination tool." Kalina was awarded Patent No.1,093,432 on April 14, 1914 for his combined "key ring, scissors, button hook, cigar cutter and bottle opener."

"The combination tool takes up very little room at the time the several devices are in folded position" so it "can be conveniently carried in a vest pocket," the patent papers said. The tool, which when extended is 5 1/4-inches long, is marked: **HESJAH TRADE MARK PAT. APRIL 14, 1914.** The patent papers also gave this advice for removing caps from bottles: "It is necessary to first unlock the scissors H and swing the same into open position to allow free use of the opening A for opening the bottle." Pabst Blue Ribbon Beer is marked on the example shown.

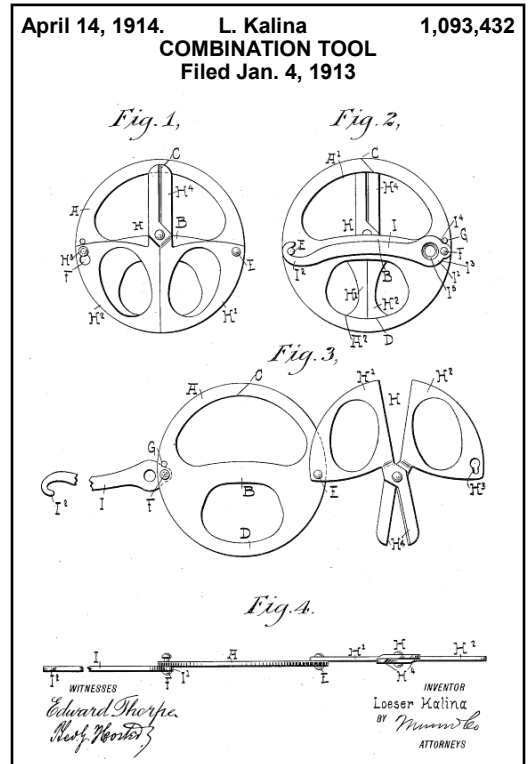

Just For Openers January-December 2025 2

Loeser Kalina: Vest Pocket Tool Czar

By Don Thornton

Kalina, who was born in Russia in 1873 and emigrated to the U.S., helped form the New York company that began manufacturing the tool in 1913. News reports at the time said Kalina, Joseph A. Hyman and Michael McDonald incorporated Hesjah Manufacturing Company with a capital stock of \$15,000 “to manufacture coat hangers and novelties.”

Hesjah launched a newspaper ad blitz in 1914 looking for agents to sell its half-dollar size “5 in 1.” Classified ads were taken out in newspaper ranging from the *Sioux City Journal* in Iowa to the *Bangor Daily News* in Maine to *The Tennessean* in Nashville.

TAKE our word for it that 5 in 1 is the biggest agent's proposition of the year; smallest pocket scissors, key ring, cigar cutter, bottle opener, buttonhook, all 5 in 1; article about the size of half dollar; fine steel; just out; don't waste time on worked-out goods; send dime for sample and particulars. M. E. Hesjah Manufacturing Company, 21 Park Row, New York. 27*

Hesjah also manufactured and sold Kalina's “Midget” telescoping/folding garment hanger. Kalina was granted Patent No. 1,049,867 on January 7, 1913 for “an improved garment hanger for supporting coats, vests, suit, trousers, skirts, waists and other garments, and adapted to be folded into a comparatively small space for convenient carrying in a vest pocket or stowing it away in a traveling bag or other similar traveling article.” The 1 by 3 inches (when folded) hanger is marked in tiny type on one end: **MIDGET TRADE MARK PAT. JAN. 7, 1913**. The cleverly engineered hanger telescopes out and unfolds to 13 inches across and 6-inches high. A newspaper ad in 1914 listed the retail price at 25 cents and said: “Will fold up to tiny dimensions of 1 x 3 inches. Can be carried in pocket or purse.”

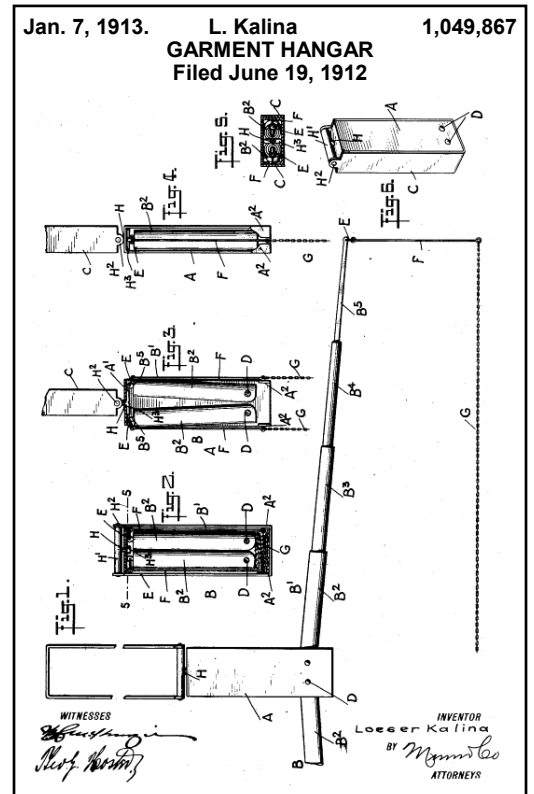

“Midget” Garment Hanger

Can be carried in the vest pocket when folded, when open makes the most useful and convenient garment hanger yet offered. Made of steel, nickel plated. By carrying one or more Midgets with you, you can keep your garments in good shape no matter where you are. For men and women alike. Call at our Notion Department and have them demonstrated to you. Price is 25c.

Loeser Kalina: Vest Pocket Tool Czar

By Don Thornton



SIDEBAR: In a letter to the editor of the Brooklyn Daily Eagle published February 24, 1931 in the Great Depression Kalina thoughtfully championed a six hour work day, saying in part:

Prosperity will return as soon as steady employment is found for the jobless. A 100 percent purchasing power will drive out any business depression.

A six-hour working day would open employment to an additional 25 percent of our working population. Opposition to the six-hour day is based purely on the idea that all merchandise will have to be sold at a much higher price, or that a large slice of the manufacturers' profit will have to be cut.

But if we can prove to the public that the six-hour day will not increase the selling price and will add a great deal to the manufacturer's profit, then the six-hour day will be a blessing to the community.