

***Just For Openers* January-December 2026 1**

Cornelius Titus Williamson Co.'s

Confidential Tribute By Don Thornton

Who is that well-dressed gentleman with a balding head and flowing white beard with a corkscrew worm for his legs? His image is finite – possibly appearing only once in a black and white advertisement in an 1899 trade magazine. There also is what could be a one-of-a-kind color illustration of him.

CORKSCREWS?
---YES, ALL STYLES.

Big and little,
great and small.



For lean purses,
for fat purses.

Yes!—
Corkscrews for all.

Just watch this space for
some of the "Leaders."

THE WILLIAMSON W. N. CO.,
Newark, N. J.

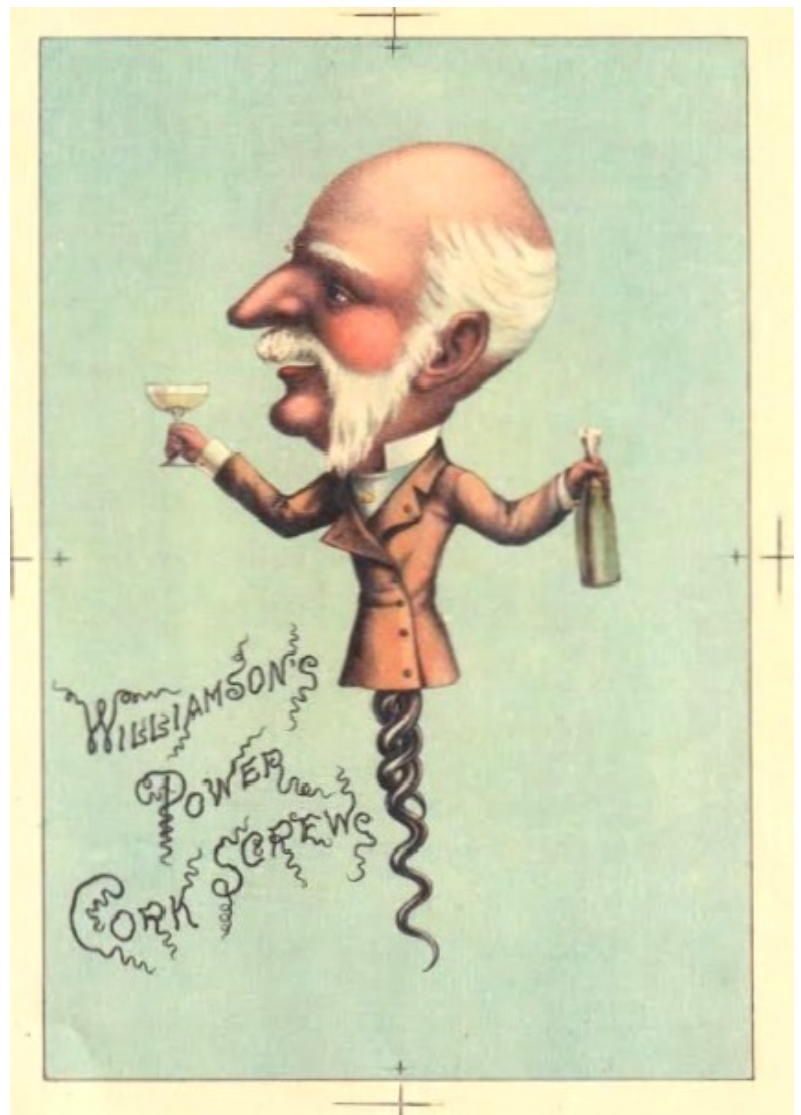

The advertisement appeared in the August 10, 1899 edition of *HARDWARE*, a popular trade magazine of the day. The cleverly worded ad features the man holding a corkscrew in one hand and a bottle of wine in the other. The ad was for the Williamson Company of Newark, New Jersey.

The 8-by-11-inch picture is in the vast library of Don Bull, who found it in a random collection he purchased at some point in his years gathering corkscrews and other openers. In the picture, the gent is holding a glass of wine instead of a corkscrew, but the advertising message is the same. The squiggly text reads: "Williamson's Power Cork Screws."

***Just For Openers* January-December 2026 2**

Cornelius Titus Williamson Co.'s

Confidential Tribute By Don Thornton

The history of Williamson corkscrews dates back to 1876 when Cornelius Titus Williamson launched his company in Newark, New Jersey to manufacture household goods. His product line later included tools he patented, a spoon corkscrew and a folding corkscrew (see below).

Williamson's son, William A. Williamson, joined the firm a year later at the age of 25 and during his career was awarded nine patents, four for corkscrews and one for a related cap lifter or cutting tool (see below). His other patents included a fruit jar, sash lift, wall wardrobe hook, ceiling wardrobe hook and can opener.

Following a business association with prolific corkscrew inventor William R. Clough and the acquisition of Edwin Walker's Erie Specialty Company (see JFO 2025 *The Twists and Turns of Walker's Erie Specialty Co.*) the C. T. Williamson Company was one of the largest producers of corkscrews in the country for years.

C. T. retired in 1888 and died eight years later. A death notice in the May 9, 1896 *New York Daily Tribune* said he passed away on May 7 of that year at the age of 73. "Funeral services at his late residence, No. 11 South St. on Monday, at 10:30 a.m. Relatives and friends are invited to attend," the newspaper reported. The company continued under William and William's sons, George and Cornelius, until it was sold in 1946 and moved to Belleville, New Jersey. It went belly up in 1982.

But back to the man with the flowing white beard and worm for legs. Possible clues to his identify include the corkscrew he is holding in the advertisement. It appears to be a company corkscrew patented by William in 1897, Patent No. 587,900. Another clue, the worm for legs, keeps it all in the family. It appears to be based on a patent by Clough owned by the Williamson company, Patent No. 172,868.

The 'keeping it in the family' premise points to the caricature being that of Cornelius Titus Williamson with son William paying a cheerful tribute to his father three years after his death. And adding to that premise is the lighthearted message with the drawing: "CORKSCREWS? ... YES, ALL STYLES. Big and little, great and small. For lean purses, for fat purses. Yes! Corkscrews for all."

FOOTNOTE: The advertisement also said in smaller type: "Just watch this space for some of the 'Leaders.'" The next two Williamson ads in *HARDWARE* listed 'leaders' with the headlines: **CORKSCREWS?...Yes, All Styles** and **"Harping, Still Harping" CORKSCREWS.**

CORKSCREWS?
---YES, ALL STYLES.
Another "Leader."
No 8782



KEEP TURNING.
NEED NOT PULL.

Combination Seal & Crown Opener.
—●—
Wire Breaker; also Cork Extractor.

A Postal receives early response.

THE WILLIAMSON W. N. CO.,
Newark, N. J.

"Harping, Still Harping"
CORKSCREWS.
Still Another "Leader."
No 1242.



KEEP TURNING.
NEED NOT PULL.

The old Story:
Flat Bottom Cup.
—●—
Loose on Screw
—●—
A Direct Pull.

For Full Particulars write

THE WILLIAMSON W. N. CO.,
Newark, N. J.

Just For Openers January-December 2026 3

Cornelius Titus Williamson Co.'s

Confidential Tribute By Don Thornton

Sept. 12, 1882. C. T. Williamson 264,391
COMBINED SPOON AND CORKSCREW
Filed June 12, 1882

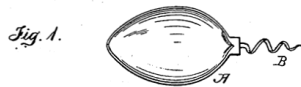
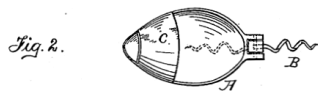

Witnesses:
Chas. Bill
Wassman Guston

Inventor:
C. T. Williamson,
By his Attorney,
Rowland G.

Mar. 27, 1883. C. T. Williamson 274,539
CORKSCREW
Filed December 8, 1882

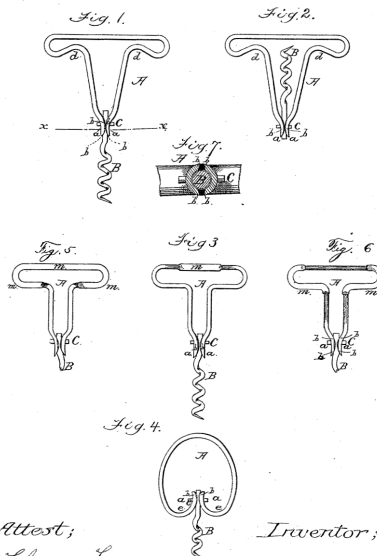

Attest:
Charles Fowler,
Chas. Bill

Inventor:
C. T. Williamson

Dec. 13, 1898. W. A. Williamson Des. 29,798
CAP LIFT
Filed October 25, 1898

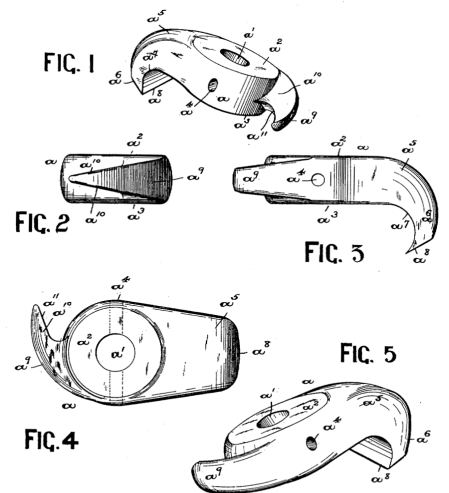

WITNESSES:
Walter H. Gahmge,
Brenton Russell

INVENTOR:
WILLIAM A. WILLIAMSON
BY
Fred C. Trautzel,
ATTORNEY

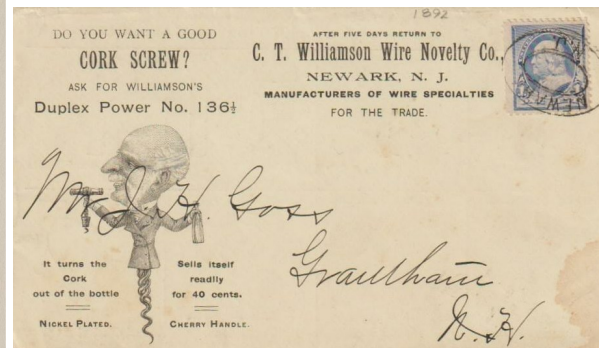
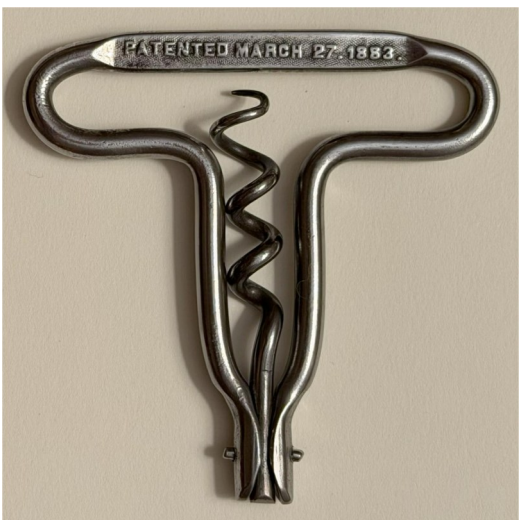

Just For Openers January-December 2026 4

Cornelius Titus Williamson Co.'s

Confidential Tribute By Don Thornton

June 18, 1889. W. A. Williamson 405,385
CORKSCREW
Filed January 12, 1888

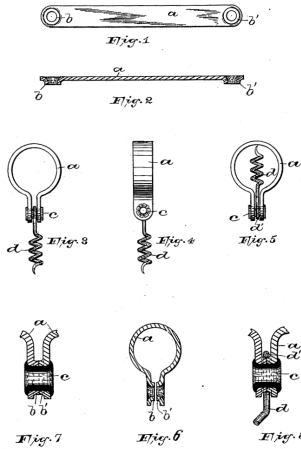

WITNESSES:
Schuyler M. ...
E. T. Kettner

INVENTOR:
W. A. Williamson
BY *Campbell & Co.* ATTYS.

June 1, 1897. W. A. Williamson 583,561
CORKSCREW
Filed January 11, 1897

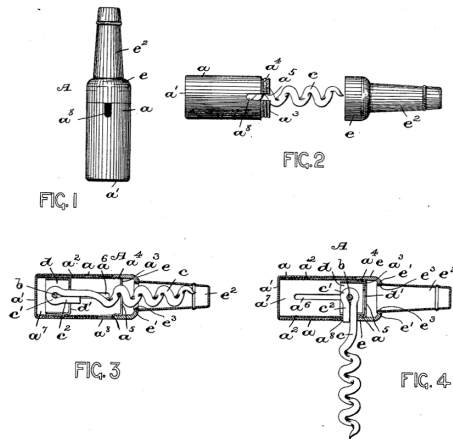

WITNESSES:
Marcy J. Drisdell
William H. Campfield J.

INVENTOR:
WILLIAM A. WILLIAMSON
BY *Fred C. Grantzel,*
ATTORNEY

Aug. 10, 1897. W. A. Williamson 587,900
CORKSCREW
Filed December 8, 1896

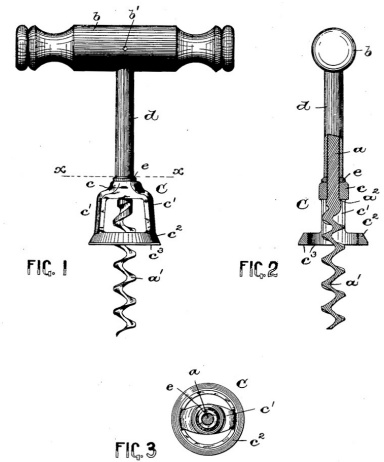

WITNESSES:
Schuyler M. ...
Wm. H. Campfield J.

INVENTOR:
WILLIAM A. WILLIAMSON,
BY *Fred C. Grantzel,*
ATTORNEY



Dec. 13, 1898. W. A. Williamson 615,938
CORK EXTRACTOR
Filed October 2, 1897

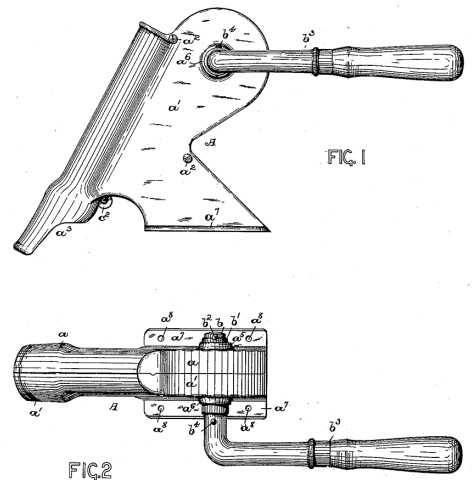

WITNESSES:
Wm. H. Campfield J.
Marcy J. Drisdell

INVENTOR:
WILLIAM A. WILLIAMSON,
BY *Fred C. Grantzel,*
ATTORNEY